

# HONG KONG ATTAINMENT TEST

## 香港學科測驗

# Mathematics 數學

## Primary 5 五年級

### Mock Paper of the Latest Question Types

### 最新題型增值卷

| 題號 | 學習重點            | 範疇    | 題號                           | 學習重點           | 範疇    |
|----|-----------------|-------|------------------------------|----------------|-------|
| 1  | 多位數 (5 上)       | 數     | 24                           | 圖形的面積 (5 上)    | 度量    |
| 2  | 整數乘法 (4 上)      |       | 25                           | 立體的體積 (5 下)    |       |
| 3  | 整數除法 (4 上)      |       | 26                           | 立體的體積 (5 下)    |       |
| 4  | 因數 (4 上)        |       | 27                           | 複合棒形圖 (5 上)    | 數據處理  |
| 5  | 公倍數和公因數 (4 上)   |       | 28                           | 棒形圖 (4 下)      |       |
| 6  | 異分母分數加法 (5 上)   |       | 29                           | 代數符號 (5 上)     | 代數    |
| 7  | 同分母分數減法 (4 下)   |       | 30                           | 解方程 (5 下)      |       |
| 8  | 分數乘法 (5 上)      |       | 31(a)                        | 異分母分數減法 (5 上)  | 數     |
| 9  | 分數除法 (5 下)      |       | 31(b)                        | 小數乘法 (5 下)     |       |
| 10 | 分數除法 (5 下)      |       | 32(a)                        | 分數四則混合計算 (5 下) |       |
| 11 | 小數的認識 (4 下)     |       | 32(b)                        | 四邊形的性質 (4 上)   | 圖形與空間 |
| 12 | 小數加減混合計算 (4 下)  |       | 33(a)                        | 解方程 (5 下)      | 代數    |
| 13 | 小數乘法 (5 下)      |       | 33(b)                        | 分數四則混合計算 (5 下) | 數     |
| 14 | 異分母分數大小比較 (5 上) |       | 34(a)                        | 複合棒形圖 (5 上)    | 數據處理  |
| 15 | 分數四則混合計算 (5 下)  |       | 34(b)                        | 複合棒形圖 (5 上)    |       |
| 16 | 圖形拼砌 (4 上)      | 34(c) | 複合棒形圖 (5 上)、<br>整數四則運算 (4 下) |                |       |
| 17 | 圓的認識 (5 下)      | 35(a) | 立體圖形的頂點和稜 (5 下)              | 圖形與空間          |       |
| 18 | 正方體的摺紙圖樣 (5 下)  | 35(b) | 立體圖形的截面 (5 下)                |                |       |
| 19 | 立體圖形的頂點和稜 (5 下) | 36(a) | 長方體的體積 (5 下)                 | 度量             |       |
| 20 | 方向 (4 上)        | 36(b) | 整數四則混合運算 (4 下)               | 數              |       |
| 21 | 周界 (4 上)        |       |                              |                |       |
| 22 | 多邊形的面積 (5 上)    |       |                              |                |       |
| 23 | 面積 (4 下)        |       |                              |                |       |

Time allowed for the test: 50 minutes

測驗時間：50 分鐘

**Instructions:**

1. This test contains two sections:

Section A: Questions 1-30

Section B: Questions 31-36

2. Answer ALL questions.

3. Write your answers on the answer sheet.

4. Write your name, class and class number on the answer sheet.

5. You may do your rough work in the blank space of this test booklet and there is no need to rub it out after the test.

6. You can use a pencil or a black/blue ball pen to answer the questions.

7. The use of calculator is not allowed.

**學生須知：**

1. 本測驗卷共有兩部分：

甲部：第 1 至第 30 題

乙部：第 31 至第 36 題

2. 全部題目均須作答。

3. 把答案寫在答題紙上。

4. 在答題紙上填寫學生姓名、班別及學號。

5. 學生可利用本測驗卷的空白部分做算草，測驗完畢後無須將算草擦去。

6. 學生可以用鉛筆或黑/藍色圓珠筆作答。

7. 不准使用計算機。

Note:  
Not all diagrams are drawn to scale.

注意：  
部分附圖不依比例繪畫。

**SECTION A** (60 marks)

Choose the correct answer. You only need to write down the letter preceding the selected answer.

**甲部** (60 分)

選出正確的答案。學生只須填上所選答案前的英文字母。

1. After rounding off 3 299 989 to one of the following places, the approximate value may never be 3 300 000. What is that place?

- A. ten thousands
- B. thousands
- C. hundreds
- D. tens

1. 把3 299 989取近似值至以下其中一個位，不可能得出3 300 000。該位是什麼？

- A. 萬位
- B. 千位
- C. 百位
- D. 十位

2. There are four dozen fluorescent light sticks in one box. Each fluorescent light stick costs \$13. If Ms Chu wants to buy 15 boxes of fluorescent light sticks, how much should she pay?

- A. \$9360
- B. \$2340
- C. \$780
- D. \$624

2. 一箱熒光棒有四打。每枝熒光棒售\$13。如果朱小姐要買15箱熒光棒，她須付多少？

- A. \$9360
- B. \$2340
- C. \$780
- D. \$624

3. It took 24 minutes to print 360 documents. How many minutes would it take to print 540 documents at the same speed?

- A. 28 minutes
- B. 34 minutes
- C. 36 minutes
- D. 38 minutes

3. 印製360份文件用了24分鐘。如果以相同的速度印製540份文件，要用多少分鐘？

- A. 28分鐘
- B. 34分鐘
- C. 36分鐘
- D. 38分鐘

4. One of the following numbers has a different number of factors than the other three numbers. What is the result of adding up all the factors of that number?

14

25

- A. 24
- B. 31
- C. 40
- D. 54

4. 以下四個數中，其中一個數的因數數量和其他三個數不同。該數所有因數相加的結果是多少？

27

34

- A. 24
- B. 31
- C. 40
- D. 54

5. The number on the card is a common factor of 60 and 90. It's also a common multiple of 6 and 15. Which of the following may be the number on the card?

- A. 15
- B. 30
- C. 60
- D. 90

5. 數字卡上的數是60和90的公因數，也是6和15的公倍數。以下哪一項可能是數字卡上的數？

- A. 15
- B. 30
- C. 60
- D. 90

6. If each

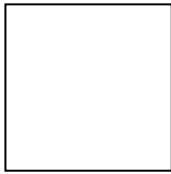

represents 1,

what is the result of adding up all the numbers represented by the shaded parts of the following figures?

6. 如果每個

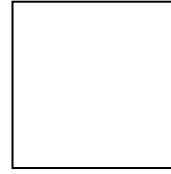

代表 1，下

列各圖形的陰影部分代表的值相加後的結果是多少？

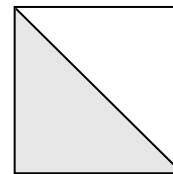
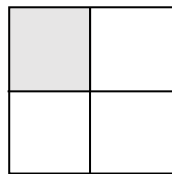
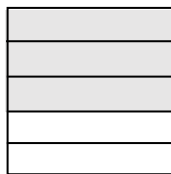

A.  $1\frac{13}{20}$

B.  $1\frac{7}{20}$

C.  $\frac{19}{24}$

D.  $\frac{5}{11}$

A.  $1\frac{13}{20}$

B.  $1\frac{7}{20}$

C.  $\frac{19}{24}$

D.  $\frac{5}{11}$

7. If  $\frac{4\Box}{5} - \frac{\star}{5} = 0$ , then  $4\Box - \star = ?$

- A. 4
- B. 3
- C. 1
- D. 0

7. 如果  $\frac{4\Box}{5} - \frac{\star}{5} = 0$ ，那麼，

$4\Box - \star = ?$

- A. 4
- B. 3
- C. 1
- D. 0

8. There are 96 buttons in each pack,  $\frac{7}{12}$  of the buttons are red. How many red buttons are there in total if there are 14 packs?

- A. 40
- B. 56
- C. 560
- D. 784

8. 每包鈕扣有 96 粒，其中  $\frac{7}{12}$  是紅色的。如果現有 14 包鈕扣，共有紅色鈕扣多少粒？

- A. 40
- B. 56
- C. 560
- D. 784

9. Kay had 36 egg rolls originally. She ate 9 egg rolls and gave 15 egg rolls to her friends. What was the fraction of the remaining number of egg rolls to the original number of egg rolls?

- A.  $\frac{1}{3}$
- B.  $\frac{7}{12}$
- C.  $\frac{2}{3}$
- D.  $\frac{3}{4}$

9. 凱麗原有36條蛋捲，她吃了9條蛋捲，又把15條蛋捲送給朋友。餘下蛋捲的數量佔原有的幾分之幾？

- A.  $\frac{1}{3}$
- B.  $\frac{7}{12}$
- C.  $\frac{2}{3}$
- D.  $\frac{3}{4}$

10. There are 100L of soy milk. If every  $\frac{3}{5}$ L of soy milk is pured into a bottle, how many bottles of soy milk can be poured at most?

- A. 60
- B. 155
- C. 166
- D. 167

10. 現有 100L 豆奶。若把每 $\frac{3}{5}$ L 的豆奶倒成一瓶，最多可倒成豆奶多少瓶？

- A. 60
- B. 155
- C. 166
- D. 167

|  |  |
|--|--|
| <p><b>11.</b> The hundreds digit and thousandths digit of a number are '3' and '5' respectively. Which of the following may be this number?</p> <p>A. 566.63</p> <p>B. 366.65</p> <p>C. 366.665</p> <p>D. 36.635</p>   | <p><b>11.</b> 一個數的百位數和千分位數分別是「3」和「5」。以下哪項可能是這個數？</p> <p>A. 566.63</p> <p>B. 366.67</p> <p>C. 366.665</p> <p>D. 36.635</p>                                    |
| <p><b>12.</b> Amy reloaded her Octopus with \$200 and used it to pay \$126.9 for buying a handbag. After the payment, the remaining value in her Octopus was \$94.8. What was the value in Amy's Octopus before it was reloaded?</p> <p>A. \$21.7</p> <p>B. \$32.1</p> <p>C. \$105.2</p> <p>D. \$167.9</p> | <p><b>12.</b> 雅婷為八達通卡增值\$200，並用它付款\$126.9購買了一個手袋。付款後，餘額是\$94.8。雅婷的八達通卡在增值之前的金額是多少？</p> <p>A. \$21.7</p> <p>B. \$32.1</p> <p>C. \$105.2</p> <p>D. \$167.9</p> |



13. Macy wants to buy a perfume set for each of her 3 friends. If there are 4 bottles of perfume in each set and the price of each bottle of perfume is \$75.6, how much should she pay in total?

- A. \$907.2
- B. \$708.4
- C. \$680.4
- D. \$302.4

13. 樂美為3位朋友每位購買一套香水，每套裝中有4瓶香水。如果每瓶香水售\$75.6，她共須付多少？

- A. \$907.2
- B. \$708.4
- C. \$680.4
- D. \$302.4

| Parcel<br>包裹 | P                 | Q                 | R                  | S                |
|--------------|-------------------|-------------------|--------------------|------------------|
| Weight<br>重量 | $2\frac{3}{4}$ kg | $\frac{21}{8}$ kg | $2\frac{7}{10}$ kg | $\frac{9}{5}$ kg |

14. According to the above table, which parcel is the heaviest?

- A. P
- B. Q
- C. R
- D. S

14. 根據上表，哪件包裹最重？

- A. P
- B. Q
- C. R
- D. S

15. There were 600 paper boxes originally. 120 paper boxes were used last week,  $\frac{3}{8}$  of the remaining paper boxes were used this week. What fraction of the original paper boxes was the paper boxes used this week?

- A.  $\frac{2}{3}$
- B.  $\frac{4}{5}$
- C.  $\frac{1}{5}$
- D.  $\frac{3}{10}$

15. 原有600個紙箱。上星期用去120個，今個星期用去餘下紙箱的 $\frac{3}{8}$ 。今個星期用去的紙箱佔原有的幾分之幾？

- A.  $\frac{2}{3}$
- B.  $\frac{4}{5}$
- C.  $\frac{1}{5}$
- D.  $\frac{3}{10}$

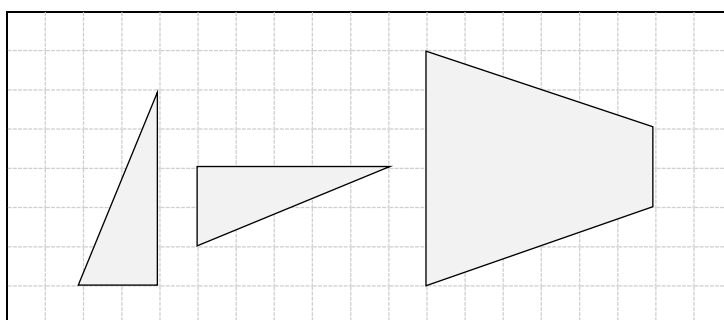

16. Which of the following shapes can be formed by using all the above figures?

- I. triangle
  - II. square
  - III. parallelogram
- A. I and II only
  - B. I and III only
  - C. II and III only
  - D. I, II and III

16. 用以上所有圖形，可以拼出以下哪些圖形？

- I. 三角形
  - II. 正方形
  - III. 平行四邊形
- A. 只有I及II
  - B. 只有I及III
  - C. 只有II及III
  - D. I、II及III

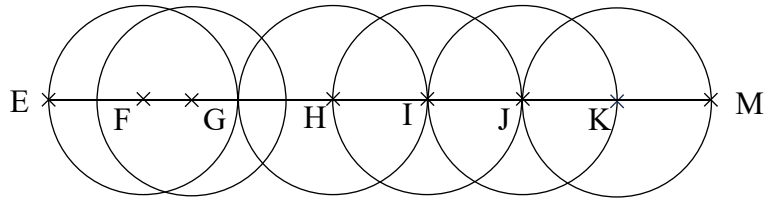



17. In the above figure, EM is a line segment passing through all the centres of the circles. If the diameter of each circle is 8cm, what is the length of EM?



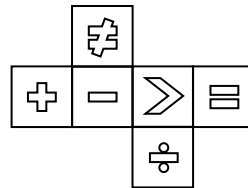

- A. 48cm
- B. 40cm
- C. 32cm
- D. 28cm

17. 上圖中，EM是一條經過所有圓心的線段。如果每個圓的直徑都是8cm，EM的長度是多少？





- A. 48cm
- B. 40cm
- C. 32cm
- D. 28cm



18. The above is the net of a cube. When it is folded into a box, the face with  is at the top. Which of the following shapes is at the bottom of the box?

- A. 
- B. 
- C. 
- D. 

18. 上圖是一個正方體的摺紙圖樣。當把它摺成盒子後，是盒子的頂部。該盒子的底部是以下哪一個圖樣？

- A. 
- B. 
- C. 
- D. 

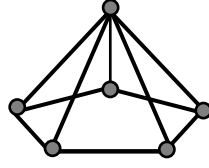

19. The above pentagonal pyramid is formed by 10 sticks of the same length and 6 plastic beads. This pentagonal pyramid is restructured to form three triangular pyramid. How many extra sticks and plastic beads are needed at least?

- A. 4 sticks and 2 plastic beads
- B. 8 sticks and 6 plastic beads
- C. 17 sticks and 6 plastic beads
- D. 8 sticks and 12 plastic beads

19. 上圖的五角錐由10枝長度相同的竹簽及6粒膠珠組成。把這個五角錐分拆重組成三個三角錐，最少額外需要多少竹簽及膠珠？

- A. 4 枝竹簽及2粒膠珠
- B. 8 枝竹簽及6粒膠珠
- C. 17枝竹簽及6粒膠珠
- D. 8 枝竹簽及 12 粒膠珠

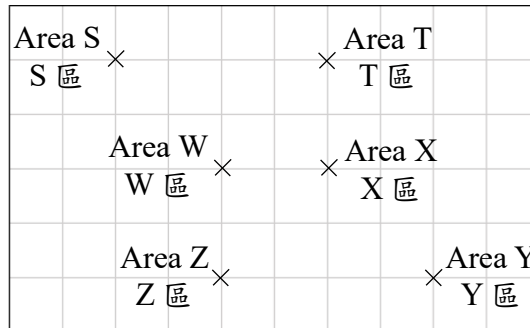

20. The above figure is the layout of the Zoo. Area T is to the southwest of Area S. Which of the following is to the west of Area X?

- A. Area S
- B. Area W
- C. Area Y
- D. Area Z

20. 以上是動物園的地圖，T區在S區的西南方，以下哪個在X區的西方？

- A. S區
- B. W區
- C. Y區
- D. Z區

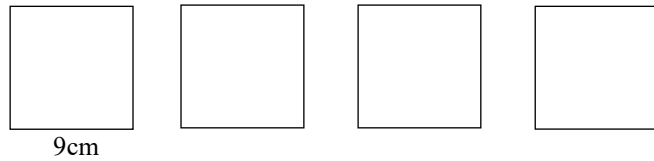

21. A new figure can be formed by using the above 4 squares of the same size together. What is the shortest perimeter of the new figure?

- A. 90cm
- B. 81cm
- C. 72cm
- D. 63cm

21. 用以上4個大小都相同的正方形拼合成一個新的圖形。新圖形的周界最短是多少？

- A. 90cm
- B. 81cm
- C. 72cm
- D. 63cm

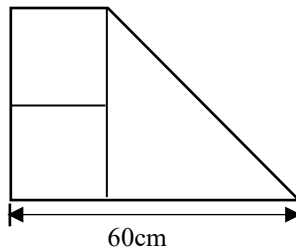

22. The above figure is formed by an isosceles right-angled triangle and two squares of the same size. What is the area of the figure?

- A.  $2400\text{cm}^2$
- B.  $2000\text{cm}^2$
- C.  $1600\text{cm}^2$
- D.  $1200\text{cm}^2$

22. 上圖由一個等腰直角三角形和兩個大小相同的正方形組成。這個圖形的面積是多少？

- A.  $2400\text{cm}^2$
- B.  $2000\text{cm}^2$
- C.  $1600\text{cm}^2$
- D.  $1200\text{cm}^2$

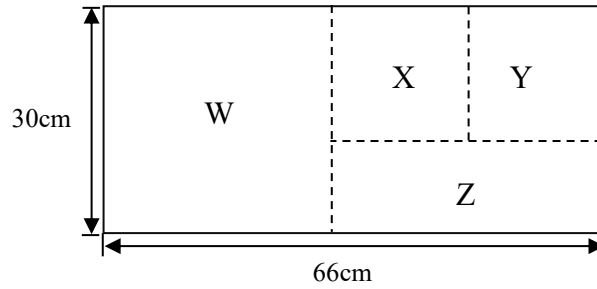

23. In the above figure, W is a big square, X and Y are two small squares of the same size. What is the area of Z?

- A.  $432\text{cm}^2$
- B.  $324\text{cm}^2$
- C.  $986\text{cm}^2$
- D.  $1208\text{cm}^2$

23. 上圖中，W是一個大正方形，X和Y是兩個大小相同的小正方形。Z的面積是多少？

- A.  $432\text{cm}^2$
- B.  $324\text{cm}^2$
- C.  $986\text{cm}^2$
- D.  $1208\text{cm}^2$

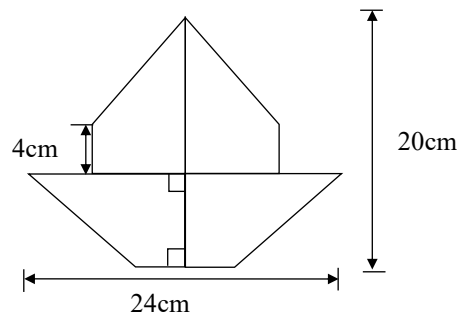

24. The above figure is formed by 4 trapeziums of the same size and same shape, what is its area?

- A.  $64\text{cm}^2$
- B.  $128\text{cm}^2$
- C.  $256\text{cm}^2$
- D.  $512\text{cm}^2$

24. 上圖由4個大小和形狀相同的梯形組成，它的面積是多少？

- A.  $64\text{cm}^2$
- B.  $128\text{cm}^2$
- C.  $256\text{cm}^2$
- D.  $512\text{cm}^2$

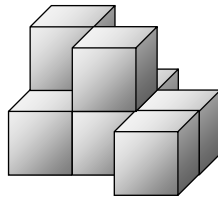

25. The above solid is formed by cubes with side 3cm. What is the volume of the whole solid?

- A.  $8\text{cm}^3$
- B.  $64\text{cm}^3$
- C.  $162\text{cm}^3$
- D.  $216\text{cm}^3$

25. 以上的立體由多個邊長 3cm 的正方體組成。整個立體的體積是多少？

- A.  $8\text{cm}^3$
- B.  $64\text{cm}^3$
- C.  $162\text{cm}^3$
- D.  $216\text{cm}^3$

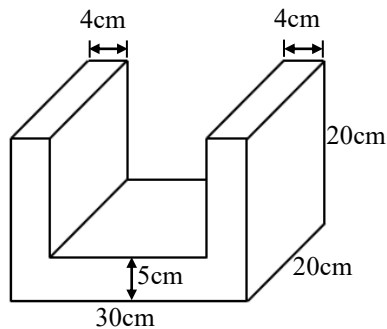

26. What is the volume of the above solid?

- A.  $4200\text{cm}^3$
- B.  $4500\text{cm}^3$
- C.  $5400\text{cm}^3$
- D.  $6000\text{cm}^3$

26. 上圖立體的體積是多少？

- A.  $4200\text{cm}^3$
- B.  $4500\text{cm}^3$
- C.  $5400\text{cm}^3$
- D.  $6000\text{cm}^3$

### Sales of Pizzas in a Pizzeria

#### 薄餅店售出的薄餅

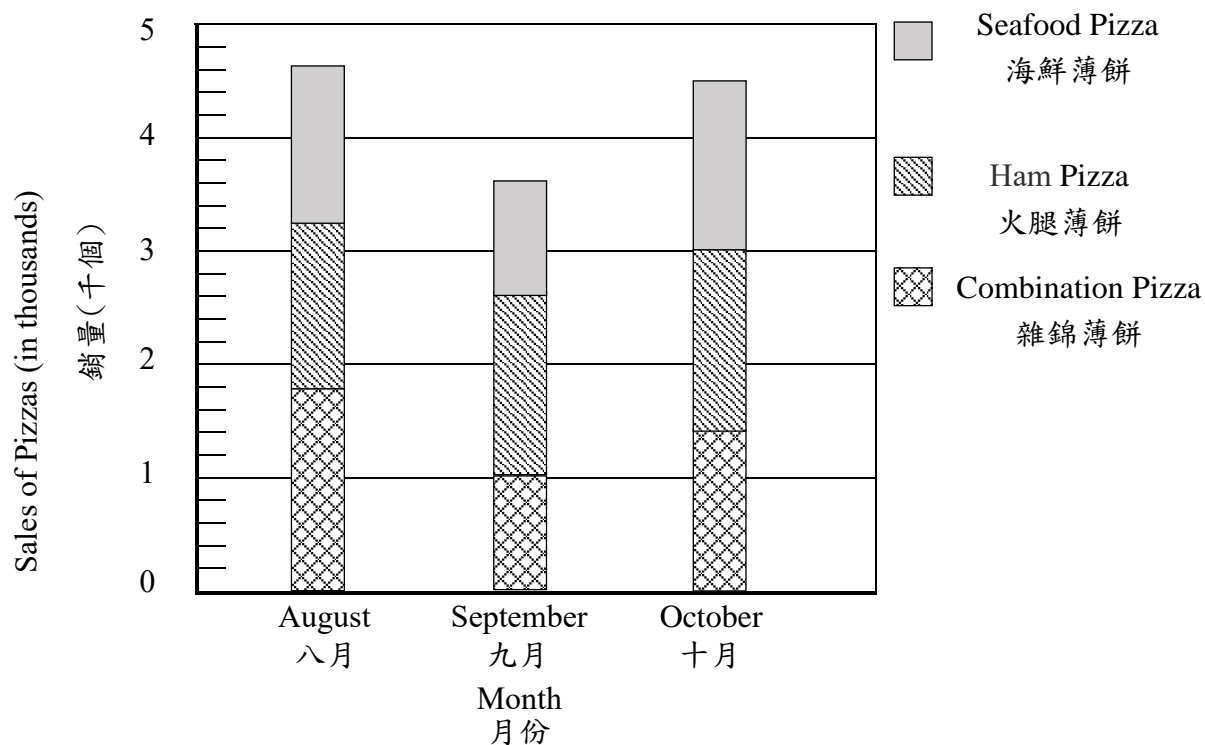

27. According to the above graph, how many more / fewer ham pizzas did the pizzeria sell in October than in August?

- A. 200 ham pizzas fewer
- B. 200 ham pizzas more
- C. 400 ham pizzas fewer
- D. 400 ham pizzas more

27. 根據上圖，十月售出的火腿薄餅比八月的多/少幾個？

- A. 少200個
- B. 多200個
- C. 少400個
- D. 多400個



Number of Spectators Watching the Basketball Match Last Week

上星期觀看籃球比賽的觀眾人數

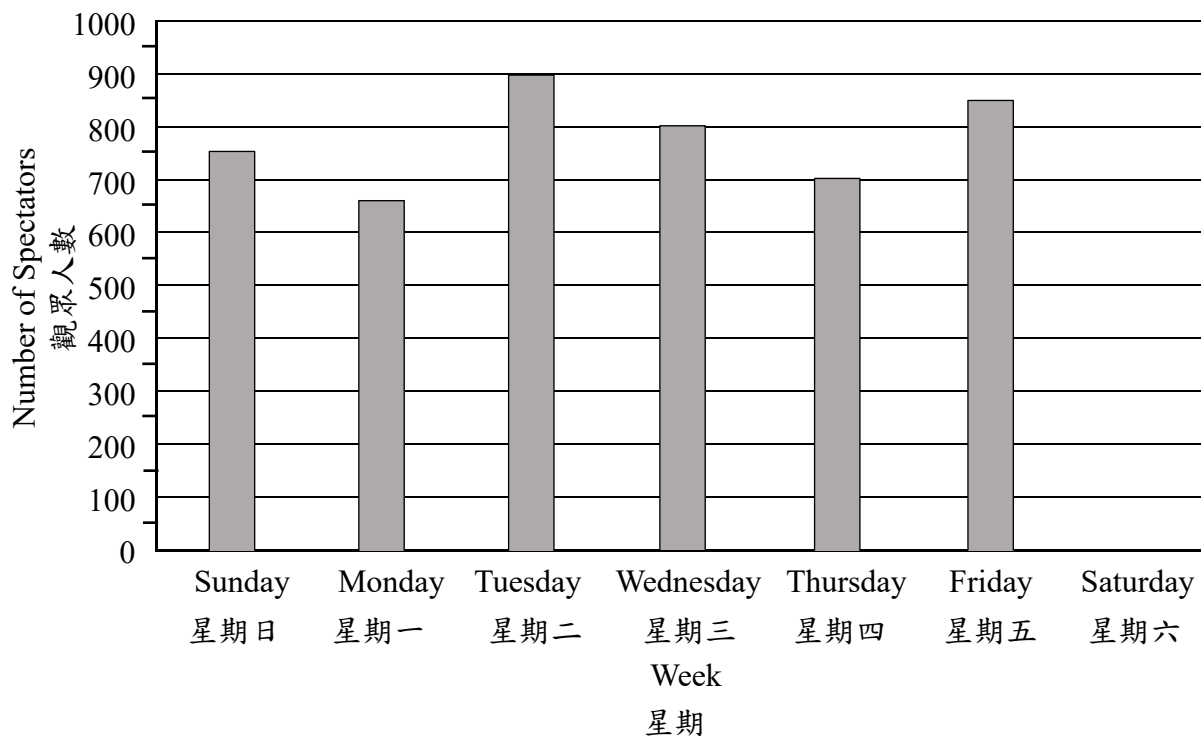

28. Jim wanted to use the above graph to show the number of spectators watching the basketball match last week. However, he forgot to indicate the number of spectators on Saturday in the graph. If the total number of spectators of the top two days was 1850, how many spectators were there on Saturday?

- A. 700
- B. 800
- C. 850
- D. 950

28. 嘉銘嘗試用上圖來表示上星期觀看籃球比賽的觀眾人數，但是忘記標示星期六的觀眾人數。如果最多觀眾的兩天共有1850人，則星期六的觀眾人數是多少人？

- A. 700
- B. 800
- C. 850
- D. 950

29. The farmer put every 36 apples into a box. He filled up  $y$  boxes and 9 apples were left. How many apples did the farmer have in total?

- A.  $36y$
- B.  $36y - 9$
- C.  $36y + 9$
- D.  $y + 324$

29. 農夫將每 36 個蘋果放一箱。他放滿  $y$  箱，並餘下 9 個蘋果。農夫共有蘋果多少個？

- A.  $36y$
- B.  $36y - 9$
- C.  $36y + 9$
- D.  $y + 324$

30. John saved  $\$m$  last month. Ann saved  $\$980$  last month, which was  $\$120$  more than 5 times of the amount saved by John. Which of the following equations can find out the value of  $m$  ?

- A.  $\frac{m}{5} - 120 = 980$
- B.  $\frac{m}{5} + 120 = 980$
- C.  $5m + 120 = 980$
- D.  $5m - 120 = 980$

30. 明輝上個月儲蓄了 $\$m$ 。美怡上個月儲蓄了 $\$980$ ，比明輝儲蓄款項的 5 倍多 $\$120$ 。以下哪一道方程可找出  $m$  的值？

- A.  $\frac{m}{5} - 120 = 980$
- B.  $\frac{m}{5} + 120 = 980$
- C.  $5m + 120 = 980$
- D.  $5m - 120 = 980$

End of Section A  
甲部完

**SECTION B** (40 marks)

Working steps must be shown in answering questions in this section, unless specified otherwise.

**乙部** (40 分)

除特別指明外，在回答本部分的問題時，須列出計算步驟。

**31. (a)** Mr Chan decided to swim for 8km a week. He swam for  $2\frac{2}{5}$  km and  $1\frac{9}{10}$  km in the first day and the second day respectively. In the remaining days, how long did he need to swim at least?  
[4 marks]

**(b)** Mr Chan swam for 265 minutes last week. He consumed 8.8 kilocalories of energy for each minute swimming. In last week, how many kilocalories of energy did Mr Chan consume by swimming in total? [4 marks]

**31. (a)** 陳先生決定一個星期游泳 8km。他在第一天和第二天分別游了  $2\frac{2}{5}$  km 和  $1\frac{9}{10}$  km。在餘下的日子，他最少須游多少？  
[4分]

**(b)** 陳先生上個星期游泳265分鐘。他游泳每分鐘消耗8.8千卡熱量。在上個星期，陳先生游泳共消耗熱量多少千卡？  
[4分]

**32. (a)** Carol had 3 packs of sticks. There were 48 sticks in each pack and  $\frac{5}{12}$  of them were not 15cm in length. How many sticks with 15cm in length did she have? (Give the answer only) [2 marks]

**(b)** Carol wanted to use the sticks with 15cm to form a rhombus. On the answer sheet, complete this rhombus. [2 marks]

**32. (a)** 依彤有 3 包膠棒。每包有 48 枝膠棒，其中  $\frac{5}{12}$  的長度不是 15cm。她有長度是 15cm 的膠棒多少枝？(只須寫出答案) [2 分]

**(b)** 依彤打算用 15cm 的膠棒組成一個菱形。在答題紙上，完成這個菱形。[2 分]

**33. (a)** In last 6 months, Aaron spent 124 hours in total on cleaning the beach. During the first 4 months, he spent  $n$  hours on cleaning the beach each month. On the last two months, he spent 28 hours on cleaning the beach each month. How many hours did he spend on cleaning the beach each of first 4 months? (Use equation to solve the problem and show working steps) [4 marks]

**33. (a)** 過去6個月，國聰用了124小時清潔海灘。在首四個月，他每個月用 $n$ 小時清潔海灘。在最後兩個月，他每個月用28小時清潔海灘。他在首四個月每個月清潔海灘用去多少時間？(須用方程列式計算，並展示步驟) [4分]

---

Environmental Donation Scheme

環保捐款計劃

After the donor's donation is deducted by \$200, the organization will use  $\frac{3}{4}$  of the remaining donation on the work of environmental protection.

捐贈者的捐款減去\$200後，機構會將餘額的 $\frac{3}{4}$ 用於環境保護工作上。

**33. (b)** Aaron donated \$960 to the environmental organization. He believed that more than \$550 from his donation would be used on the work of environmental protection according to the above donation scheme. Do you agree? Explain. [4 marks]

**33. (b)** 國聰向該環保機構捐贈了 \$960。他認為根據以上捐款計劃，自己的捐款中有多於\$550會用於環保工作。你同意嗎？試解釋。 [4分]

Number of New Members of Fitness Center

健身中心的新會員人數

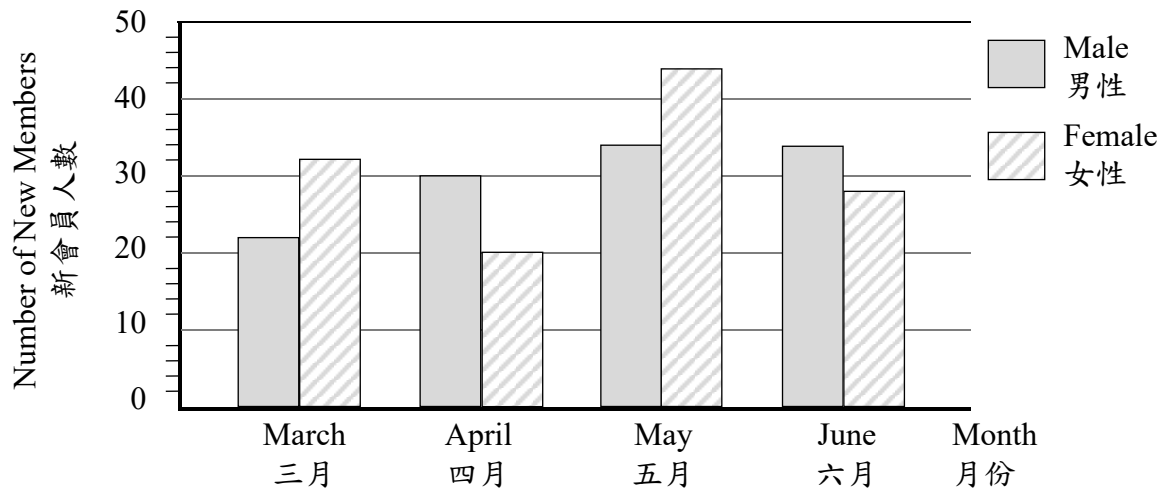

**34. (a)** In which month did fitness center have the largest number of new members? How many new members were there in total? (Give the answer only)  
[2 marks]

**(b)** If the number of new members in a month was 60 or above, each employee would be awarded a bonus. How many bonuses were awarded to each employee from March to June in total? (Give the answer only)  
[2 marks]

**34. (a)** 健身中心哪一個月的新會員人數最多？共有新會員多少人？(只須寫出答案) [2分]

**(b)** 如果某個月的新會員人數達 60 人或以上，那麼該月每位員工可獲得一份獎金。健身中心的每位員工在三月至六月共可獲得獎金多少份？(只須寫出答案) [2分]

**34. (c)** The new members have to pay a membership fee of \$125 in the first month. What was the total membership fee did fitness center get in April? [4 marks]

**34. (c)** 新會員在入會首月須繳納會員費\$125，健身中心在四月共收得會員費多少？ [4分]

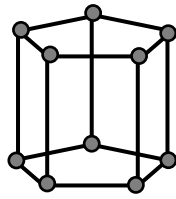

Figure 1

圖一

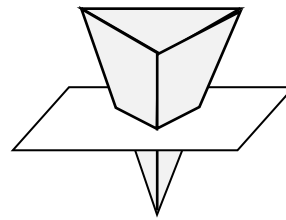

Figure 2

圖二

**35. (a)** Linda makes the solid in Figure 1 using sticks and plastic beads. What solid is it? How many sticks and plastic beads are used? (Give the answer only)

[2 marks]

**(b)** As shown in Figure 2, a cross section being parallel to the base is cut from a triangular pyramid. What is the shape of this cross section? Is the shape and size of this cross section the same as that of the base?

[2 marks]

**35.(a)** 樂琪用竹簽和膠珠製作了圖一的立體。這個立體是什麼？用了竹簽和膠珠多少？ [2分]

**(b)** 圖二所示，三角錐被切出一個平行於底的截面。這個截面是什麼形狀？它的形狀和大小是否和底相同？ [2分]

36. Alisa wants to buy puddings and Cakes for a birthday party.

36. 彩玉想為生日派對購買一些布甸和蛋糕。

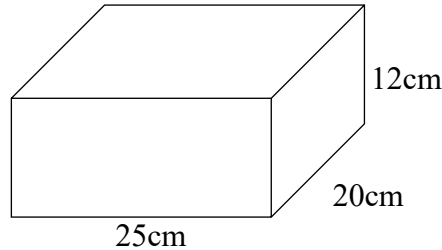

(a) The above figure is the cake box to be used by Alisa. What is the volume of this cake box?  
[4 marks]

(a) 上圖是彩玉要用的蛋糕盒。這個蛋糕盒的體積是多少？  
[4分]

| Pudding<br>布甸 | Price<br>售價 | Cake<br>蛋糕                                 | Price<br>售價 |       |
|---------------|-------------|--|-------------|-------|
| Each<br>每個    | \$15        | Weight per cake<br>not over<br>每個重量<br>不超過 | 5 oz<br>安士  | \$90  |
|               |             |  | 6 oz<br>安士  | \$120 |
|               |             |  | 7 oz<br>安士  | \$145 |

(b) Alisa bought 12 puddings and 4 cakes with 6.5 oz each. According to the above table, how much should she pay?  
[4 marks]

(b) 彩玉購買了12件布甸和4個各重6.5安士的蛋糕。根據上圖，她須付款多少？  
[4分]

**End of Test Paper**  
測驗卷完



