

HONG KONG ATTAINMENT TEST
香港學科測驗

Mathematics 數學

Primary 6 六年級

Mock Paper of the Latest Question Types
最新題型增值卷

題號	學習重點	範疇	題號	學習重點	範疇
1	多位數(5上)	數	25	折線圖(6下)	數據處理
2	乘法(4上)		26	複合棒形圖(5下)	
3	倍數和因數(4上)		27	棒形圖(6上)	
4	公倍數和公因數(4上)		28	平均數(6上)	
5	分數的認識(3下)		29	代數式(5上)	代數
6	異分母分數加法(5上)		30	簡易方程(5下)	
7	分數乘法(5上)		31(a)	象形圖(5上)	數據處理
8	分數除法(5下)		31(b)	折扣(6下)	數
9	小數減法(5下)		31(c)	簡易方程(6下)	代數
10	小數加法(5下)		32(a)	面積(5上)	度量
11	百分數的認識(6上)		32(b)	除法(4上)	數
12	百分數的應用(6下)		33(a)	對稱(4下)	圖形與空間
13	四邊形(4上)		33(b)	周界(4上)	
14	八個方向(5上)	34(a)	小數四則混合計算(6上)	數	
15	圓的認識(6下)	34(b)	折扣(6下)		
16	摺紙圖樣(5下)	35(a)	異分母分數減法(5上)		
17	立體圖形(6上)	35(b)	百分數的應用(6下)	度量	
18	周界(4上)、面積(4下)	35(c)	速率(6下)		
19	圓周(6下)	36(a)	八個方向(5上)	圖形與空間	
20	面積(5上)	36(b)	整數四則混合計算(4下)	數	
21	體積(5下)	36(c)	小數乘法(5下)		
22	不規則立體的體積(6上)				
23	容量和體積(6上)				
24	速率(6下)				

Time allowed for the test: 50 minutes

測驗時間：50 分鐘

Instructions:

1. This test contains two sections:
Section A: Questions 1-30
Section B: Questions 31-36
2. Answer ALL questions.
3. Write your answers on the answer sheet.
4. Write your name, class and class number on the answer sheet.
5. You may do your rough work in the blank space of this test booklet and there is no need to rub it out after the test.
6. You can use a pencil or a black/blue ball pen to answer the questions.
7. The use of calculator is not allowed.

學生須知：

1. 本測驗卷共有兩部分：
甲部：第 1 至第 30 題
乙部：第 31 至第 36 題
2. 全部題目均須作答。
3. 把答案寫在答題紙上。
4. 在答題紙上填寫學生姓名、班別及學號。
5. 學生可利用本測驗卷的空白部分做算草，測驗完畢後無須將算草擦去。
6. 學生可以鉛筆或黑/藍色圓珠筆作答。
7. 不准使用計算機。

Note:
Not all diagrams are drawn to scale.

注意：
部分附圖不依比例繪畫。

SECTION A (60 marks)

Choose the correct answer. You only need to write down the letter preceding the selected answer.

甲部 (60 分)

選出正確的答案。學生只須填上所選答案前的英文字母。

<p>1. The total collection of a library is 4 500 000 books when corrected to the nearest hundred thousand and 4 550 000 books when corrected to the nearest ten thousand. Which of the following could be the possible total collection of the library?</p> <p>A. 4 543 000</p> <p>B. 4 546 000</p> <p>C. 4 553 000</p> <p>D. 4 556 000</p>	<p>1. 某圖書館藏書的總數取近似值至十萬位後為 4 500 000 本，以及取近似值至萬位後為 4 550 000 本。下列哪一個數可能是該圖書館的藏書總數？</p> <p>A. 4 543 000</p> <p>B. 4 546 000</p> <p>C. 4 553 000</p> <p>D. 4 556 000</p>
<p>2. The price of a notebook is \$32. One extra free notebook will be given when buying 5 notebooks. Miss Chan needs to buy 25 notebooks, how much should she pay at least?</p> <p>A. \$640</p> <p>B. \$672</p> <p>C. \$768</p> <p>D. \$800</p>	<p>2. 一本筆記簿的售價是\$32，購買 5 本可額外獲贈一本。陳小姐需購買 25 本筆記簿，她最少須付多少？</p> <p>A. \$640</p> <p>B. \$672</p> <p>C. \$768</p> <p>D. \$800</p>

<p>3. All factors of H are: $1, 3, 13, H$</p> <p>Which of the following is not a multiple of H?</p> <p>A. 52 B. 78 C. 117 D. 156</p>	<p>3. H 的所有因數是： $1、3、13、H$</p> <p>以下哪一個不是 H 的倍數？</p> <p>A. 52 B. 78 C. 117 D. 156</p>
<p>4. 6,8,9 are used to form the smallest 3-digit number which is a multiple of 8. Each number should not be used repeatedly. What is the H.C.F. of that 3-digit number and 96?</p> <p>A. 12 B. 28 C. 32 D. 96</p>	<p>4. 用 6、8、9 組成一個最小的三位數，且該數是 8 的倍數，每個數字不可重複使用。該三位數和 96 的 H.C.F. 是多少？</p> <p>A. 12 B. 28 C. 32 D. 96</p>

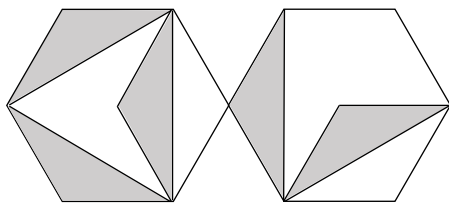

5. The above figure is formed by 2 regular hexagons of the same size. What fraction of the whole figure is shaded?

- A. $\frac{1}{2}$
- B. $\frac{5}{12}$
- C. $\frac{5}{14}$
- D. $\frac{1}{3}$

5. 上圖是由 2 個大小相同的正六邊形組成。陰影部分佔全圖的幾分之幾？

- A. $\frac{1}{2}$
- B. $\frac{5}{12}$
- C. $\frac{5}{14}$
- D. $\frac{1}{3}$

6. There are $23\frac{1}{8}$ kg of apples in the fruit shop. The peaches are $5\frac{1}{2}$ kg heavier than the apples. What is the total weight of apples and peaches in the fruit shop?

- A. $34\frac{1}{8}$ kg
- B. $38\frac{5}{8}$ kg
- C. $50\frac{3}{8}$ kg
- D. $51\frac{3}{4}$ kg

6. 水果店有蘋果 $23\frac{1}{8}$ kg，桃子比蘋果多 $5\frac{1}{2}$ kg。水果店內共有蘋果和桃子多少？

- A. $34\frac{1}{8}$ kg
- B. $38\frac{5}{8}$ kg
- C. $50\frac{3}{8}$ kg
- D. $51\frac{3}{4}$ kg

<p>7. A roll of ribbon is $18\frac{3}{5}$m long. After half of it is used, how much is left?</p> <p>A. $8\frac{2}{3}$m B. $9\frac{3}{10}$m C. $9\frac{2}{3}$m D. $10\frac{1}{5}$m</p>	<p>7. 一卷絲帶長 $18\frac{3}{5}$m，用去一半後，還剩多少？</p> <p>A. $8\frac{2}{3}$m B. $9\frac{3}{10}$m C. $9\frac{2}{3}$m D. $10\frac{1}{5}$m</p>
<p>8. $2\frac{2}{5}$L of milk is poured into glasses of capacity of $\frac{3}{10}$L each. How many glasses can be filled?</p> <p>A. 7 B. 8 C. 9 D. 10</p>	<p>8. 有牛奶 $2\frac{2}{5}$L，可以注滿容量是 $\frac{3}{10}$L 的杯子多少隻？</p> <p>A. 7 B. 8 C. 9 D. 10</p>
<p>9. The weight of a baby is 3.25kg, and the nurse wrote it as 2.35kg by mistake. What is the difference in value between the two '3's?</p> <p>A. 0.27 B. 0.7 C. 1.3 D. 2.7</p>	<p>9. 嬰兒的體重是 3.25kg，護士錯寫成 2.35kg。兩個「3」的數值相差多少？</p> <p>A. 0.27 B. 0.7 C. 1.3 D. 2.7</p>

10. Which of the following has the largest value?

- A. $5.5 + 5 + 0.05$
- B. $55 + 5.05 + 0.05$
- C. $55 + 5.05 + 0.5$
- D. $55 + 0.5 + 0.55$

10. 下列哪一項的值最大？

- A. $5.5 + 5 + 0.05$
- B. $55 + 5.05 + 0.05$
- C. $55 + 5.05 + 0.5$
- D. $55 + 0.5 + 0.55$

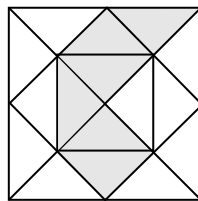

11. What is the percentage of the shaded part to the whole figure above?

- A. 30%
- B. 35%
- C. 37.5%
- D. 60%

11. 上圖的陰影部分佔全圖的百分之幾？

- A. 30%
- B. 35%
- C. 37.5%
- D. 60%

12. There are 150 students in primary six, 44% of the students are boys. If 25% of the girls wear glasses, how many girls do not wear glasses?

- A. 16
- B. 21
- C. 42
- D. 63

12. 六年級有 150 名學生，44%是男學生。在女學生中，有 25%佩戴眼鏡。未佩戴眼鏡的女學生有多少名？

- A. 16
- B. 21
- C. 42
- D. 63



13. If all of the above five plastic sticks are used together to form a quadrilateral, which of the following quadrilaterals can be formed?

- I. rectangle
 - II. parallelogram
 - III. trapezium
- A. I and II only
- B. I and III only
- C. II and III only
- D. I, II and III

13. 如果同時使用以上的五條膠棒去組成一個四邊形，可以組成以下哪些四邊形？

- I. 長方形
 - II. 平行四邊形
 - III. 梯形
- A. 只有 I 及 II
- B. 只有 I 及 III
- C. 只有 II 及 III
- D. I、II 及 III

14. Car P is 10m to the south of Car Q. Car R is 10m to the east of Car P. In which direction is Car R from Car Q?

- A. south-east
- B. north-east
- C. south-west
- D. north-west

14. 汽車 P 在汽車 Q 的南方 10m，汽車 R 在汽車 P 的東方 10m，汽車 R 在汽車 Q 的哪一方？

- A. 東南
- B. 東北
- C. 西南
- D. 西北

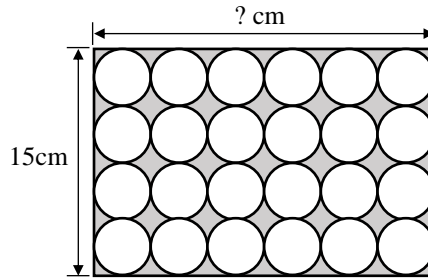

15. A rectangular box can hold 24 circular cookies of the same size, as shown above. This box is 15cm wide. What is the length of the box?

- A. $18\frac{3}{4}$ cm
- B. $20\frac{1}{4}$ cm
- C. $22\frac{1}{2}$ cm
- D. $26\frac{1}{4}$ cm

15. 一個長方形盒子可以裝 24 塊大小相同的圓形餅乾，如上圖所示。這盒子闊 15cm，它的長是多少？

- A. $18\frac{3}{4}$ cm
- B. $20\frac{1}{4}$ cm
- C. $22\frac{1}{2}$ cm
- D. $26\frac{1}{4}$ cm

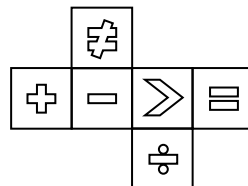

16. The above is the net of a cube. When it is folded into a box, the face with is at the top. Which of the following shapes is at the bottom of the box?

- A.
- B.
- C.
- D.

16. 上圖是一個正方體的摺紙圖樣。當把它摺成盒子後， 是盒子的頂部。該盒子的底部是以下哪一個圖樣？

- A.
- B.
- C.
- D.

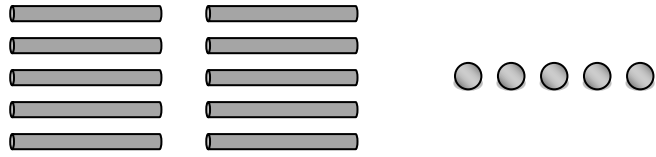

17. Which of the following solids can be formed by using the above wooden sticks and plastic balls?

- I. prism with a quadrilateral base
 - II. pyramid with a quadrilateral base
 - III. pyramid with a pentagonal base
- A. I only
 - B. II only
 - C. III only
 - D. II and III only

17. 用上面的木棒和膠珠，可以組成以下哪一個/些立體？

- I. 四角柱
 - II. 四角錐
 - III. 五角錐
- A. 只有 I
 - B. 只有 II
 - C. 只有 III
 - D. 只有 II 和 III

18. The perimeter of a rectangle is 36cm. If its length is 2 times its width, what is the area of the rectangle?

- A. 36cm^2
- B. 72cm^2
- C. 162cm^2
- D. 288cm^2

18. 長方形的周界是 36cm。如果長度是闊度的 2 倍，這個長方形的面積是多少？

- A. 36cm^2
- B. 72cm^2
- C. 162cm^2
- D. 288cm^2

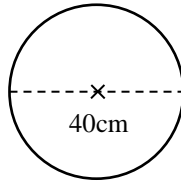

19. Each of the following figures is formed by some semi-circles or a figure of sides 20cm long and semi-circles together. Which figure below has the same perimeter as the circumference of the circle above?

19. 以下各圖形是由一些半圓或由邊長 20cm 的圖形和半圓組成。哪一個圖形的周界和上圖的圓周相同？

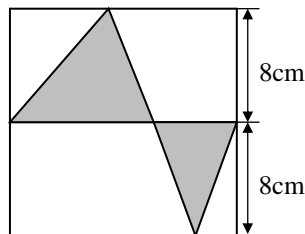
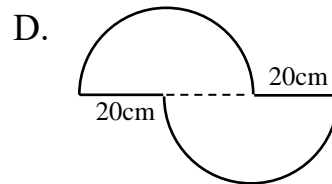
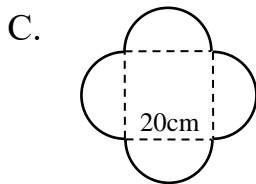
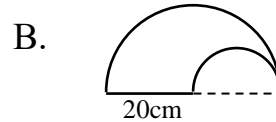
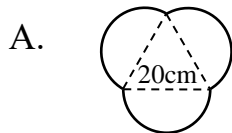

20. In the above square, what is the area of the shaded part?

20. 在上圖的正方形中，陰影部分的面積是多少？

- A. 128cm^2
- B. 96cm^2
- C. 64cm^2
- D. 32cm^2

- A. 128cm^2
- B. 96cm^2
- C. 64cm^2
- D. 32cm^2

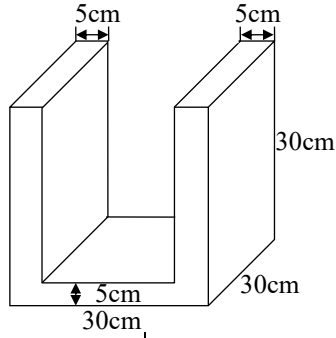

21. What is the volume of the above figure?

- A. 11250cm^3
- B. 12000cm^3
- C. 18000cm^3
- D. 18750cm^3

21. 上圖的體積是多少？

- A. 11250cm^3
- B. 12000cm^3
- C. 18000cm^3
- D. 18750cm^3

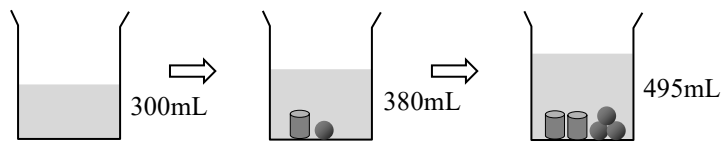

22. According to the above figures, what is the volume of one cylinder?

- A. 11cm^3
- B. 35cm^3
- C. 45cm^3
- D. 66cm^3

22. 根據上圖，一個圓柱的體積是多少？

- A. 11cm^3
- B. 35cm^3
- C. 45cm^3
- D. 66cm^3

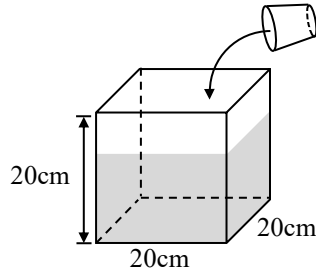

23. Henry filled up a glass with water and poured the water into the tank. After he had poured 26 glasses of water into the tank, the water level reached 65% of the height of the tank, as shown in the above figure. What is the capacity of the glass?

- A. 350mL
- B. 300mL
- C. 250mL
- D. 200mL

23. 小康把玻璃杯盛滿水並把水倒入水缸。他倒了 26 杯水入水缸後，水位達至水缸高度的 65%，如上圖所示。玻璃杯的容量是多少？

- A. 350mL
- B. 300mL
- C. 250mL
- D. 200mL

24. When my father went to work, he took 20 minutes to walk 2km. Then he ran at 2 times of his walking speed to finish 750m of the remaining journey. How long did he run?

- A. 2.5 minutes
- B. 2.75 minutes
- C. 3.5 minutes
- D. 3.75 minutes

24. 爸爸去公司上班時，他用了 20 分鐘步行了 2km。然後他以步行速率的 2 倍跑完餘下 750m 的路程。他跑了多久？

- A. 2.5 分鐘
- B. 2.75 分鐘
- C. 3.5 分鐘
- D. 3.75 分鐘

Number of Visitors to Sea Park in the First Half Year of 2021

海洋樂園 2021 年上半年的入場人數

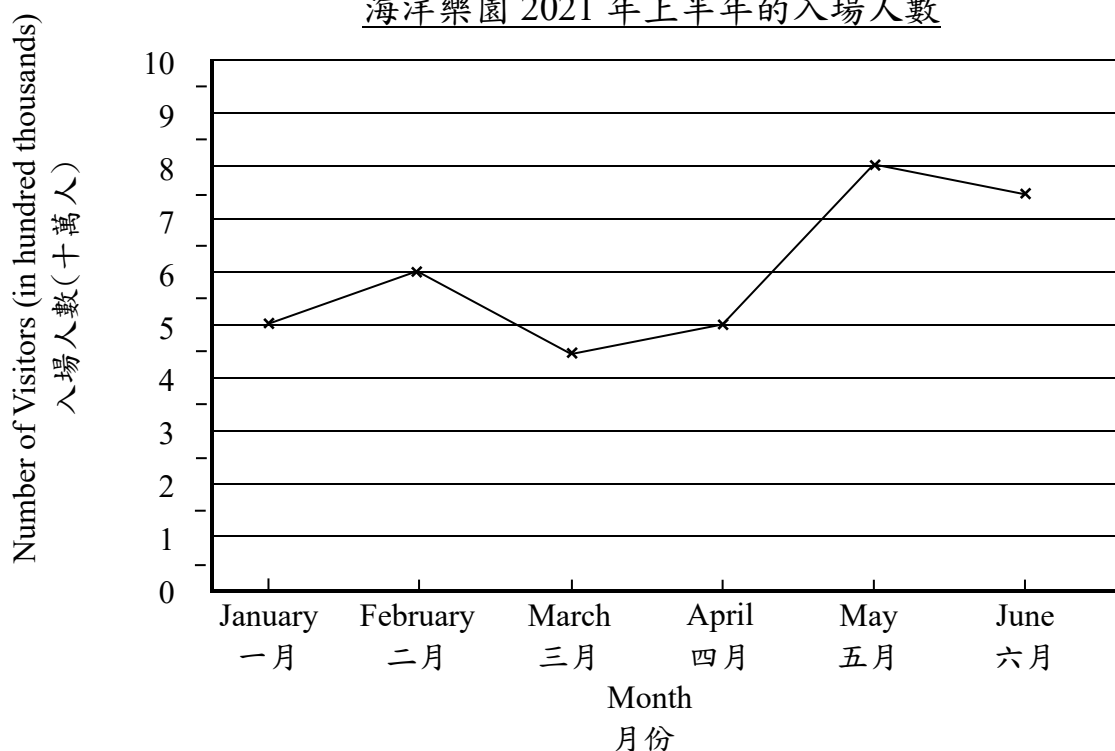

25. According to the above graph, what was the difference between the smallest number of monthly visitors and the average number of monthly visitors in the first half of the year?

- A. 200 000
- B. 150 000
- C. 100 000
- D. 50 000

25. 根據上圖，上半年中最少的每月入場人數與平均每月入場人數相差多少？

- A. 200 000
- B. 150 000
- C. 100 000
- D. 50 000

Number of Students Who were late in the Past Five Days

過去五天遲到的學生人數

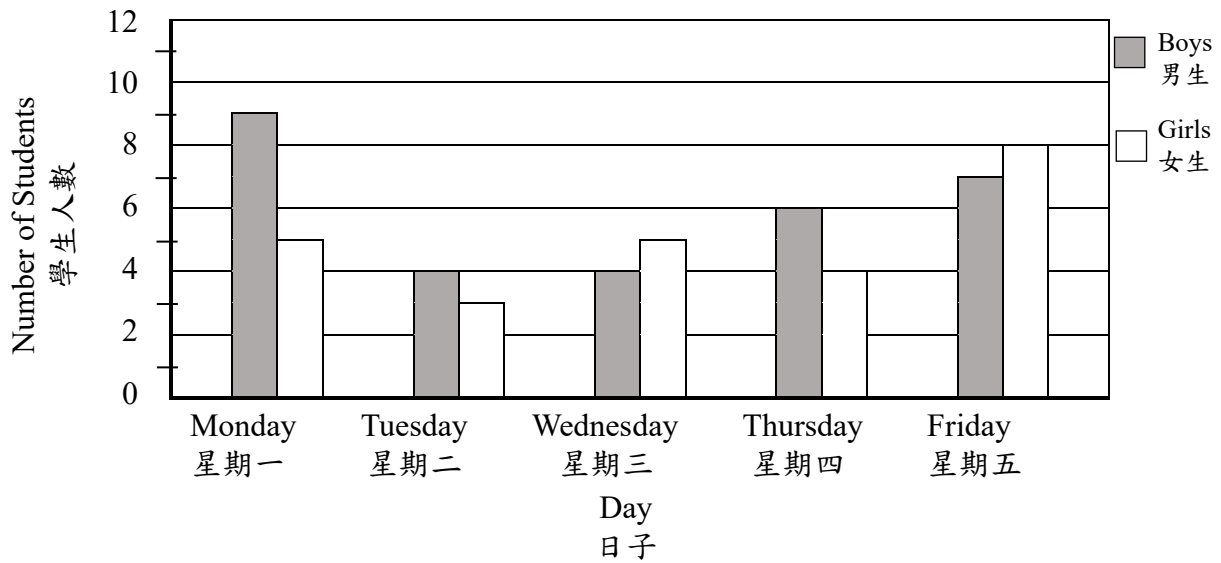

26. The above graph showed the number of students who were late in the past five days. Which day's total number of students who were late was exactly 2 times the total number of students who were late on Tuesday?

- A. Monday
- B. Wednesday
- C. Thursday
- D. Friday

26. 上圖是過去五天遲到的學生人數。哪一天的遲到人數剛好是星期二的2倍？

- A. 星期一
- B. 星期三
- C. 星期四
- D. 星期五

Sales of Shoes in the Second Half Year of a Shoe Shop

鞋店下半年鞋子的銷量

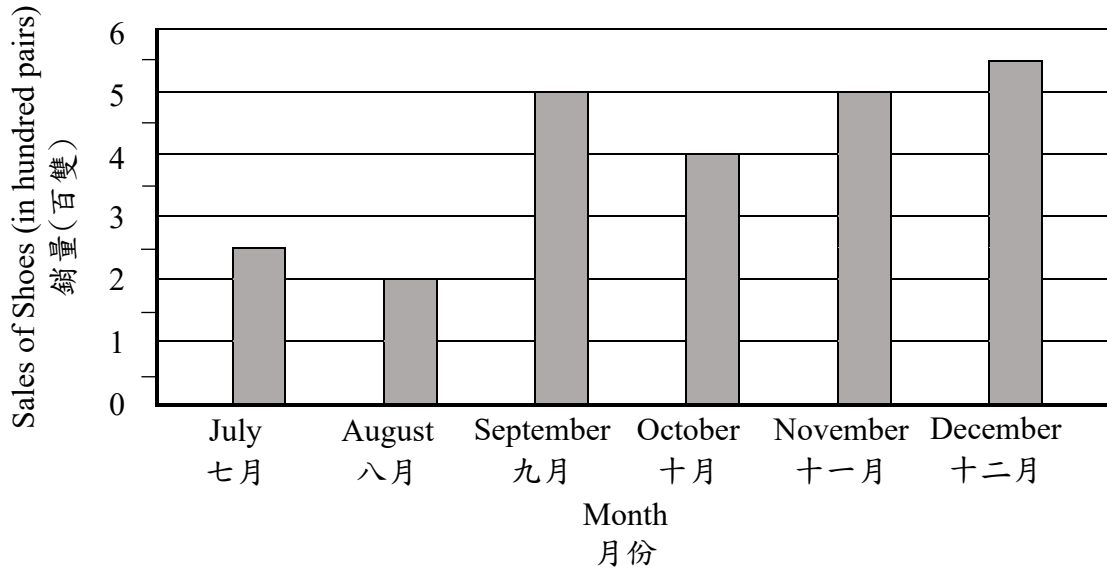

27. According to the above graph, which of the following is correct?

- A. The average sales of shoes in the second half year was 400 pairs.
- B. The average sales of shoes in the second half year was 600 pairs.
- C. The total sales of shoes in the second half year was 2500 pairs.
- D. The total sales of shoes in the second half year was 3400 pairs.

27. 根據上圖，以下哪一項是正確的？

- A. 下半年鞋子的平均銷量是 400 雙。
- B. 下半年鞋子的平均銷量是 600 雙。
- C. 下半年鞋子的總銷量是 2500 雙。
- D. 下半年鞋子的總銷量是 3400 雙。

Subject 科目	Chinese 中文	Mathematics 數學	English 英文	Average Marks 平均分
Marks 分數	88	?	96	93

28. The above table shows John's examination results. What was his mark in Mathematics?

- A. 93
- B. 95
- C. 97
- D. 99

28. 上表是子健的考試成績。他的數學科的分數是多少？

- A. 93
- B. 95
- C. 97
- D. 99

29. There were 5 participants in a camping activity. If the rental fee for hiring car was \$y and the rental fee for tents for each participant was \$85. What was the total cost for this activity?

- A. $\$(5y + 85)$
- B. $\$(y + 85)$
- C. $\$5(y + 85)$
- D. $\$(y + 425)$

29. 一個露營活動有 5 人參加。如果租車的費用是 \$y，租用帳篷的費用是每人 \$85，那麼整個活動的總費用是多少？

- A. $\$(5y + 85)$
- B. $\$(y + 85)$
- C. $\$5(y + 85)$
- D. $\$(y + 425)$

30. If $7P = 126$, then $P + 15 = ?$

- A. 48
- B. 45
- C. 33
- D. 28

30. 如果 $7P = 126$ ，那麼 $P + 15 = ?$

- A. 48
- B. 45
- C. 33
- D. 28

End of Section A

甲部完

SECTION B (40 marks)

Working steps must be shown in answering questions in this section unless specified otherwise.

乙部 (40 分)

除特別指明外，在回答本部問題時，須列出計算步驟。

31. In Happy Bookstore each atlas was sold at \$65. The following graph shown the sales of atlases in the bookstore last week.

31. 快樂書店搞優惠活動，每本地圖集售\$65。下圖是書店上星期地圖集的銷售量。

Sales of Atlases in Happy Bookstore Last Week
快樂書店上星期地圖集的銷售量

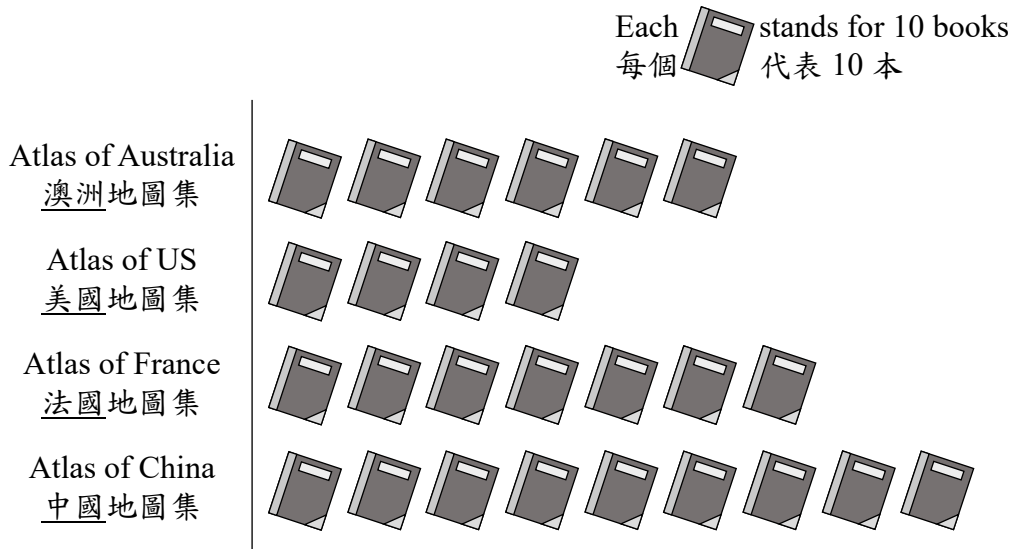

(a) According to the above graph, how much did the Happy Bookstore get last week by selling the atlases? (Give the answer only) [2 marks]

(a) 根據上圖，快樂書店上周售出地圖集所得的款項是多少？(只須寫出答案) [2分]

31. (b) Miss Lee bought 100 atlases. If the bookstore offered a 10% discount, how much should Miss Lee pay? (Give the answer only) [2 marks]

(c) Last week, the bookstore bought x world atlases. After donating 150 world atlases to the social welfare organisation, 20% of the rest were sold. If a total of 70 world atlases were sold, how many world atlases did the bookstore buy last week? (Use equation to solve the problem and show your working steps) [4 marks]

31. (b) 李老師購買了 100 本地圖集。如果書店提供九折優惠，李老師須付多少？(只須寫出答案) [2 分]

(c) 上星期，書店購進了 x 本世界地圖集。捐贈了 150 本予社福機構後，再售出餘下的 20%。如果總共售出 70 本世界地圖集，書店上月購進世界地圖集多少本？(須用方程計算並列出步驟) [4 分]

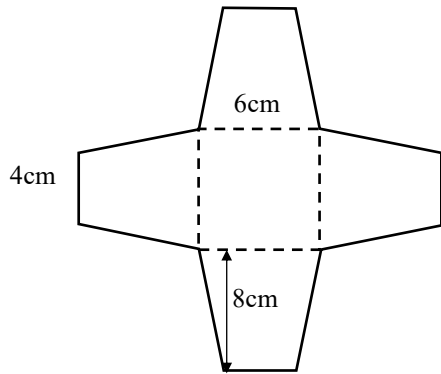

Figure 1
圖一

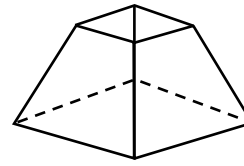
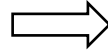

Figure 2
圖二

32. The plastic sheet in Figure 1 is formed by one square and four trapeziums of the same size and shape. Nancy used this plastic sheet to fold into the bottle in Figure 2.

(a) In Figure 1, what is the area of the plastic sheet? [4 marks]

(b) In Figure 2, the capacity of the bottle is 200cm^3 . If Nancy uses this kind of bottle to hold 840cm^3 of vinegar, how many bottles can be fully filled at most? (Give the answer only) [2 marks]

32. 圖一的膠片是由一個正方形及四個大小和形狀相同的梯形組合而成。敏儀利用該膠片摺成圖二的瓶子。

(a) 在圖一，膠片的面積是多少？ [4分]

(b) 在圖二，這個瓶子的容量是 200cm^3 。如果敏儀用這款瓶子去盛載 840cm^3 的醋，她最多可盛滿多少瓶？(只須寫出答案) [2分]

33. Amy used 16 equilateral triangles of the same size to form the shapes in Figure 1 and Figure 2.

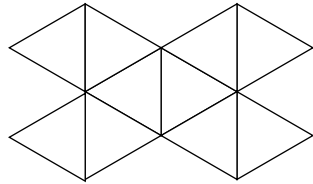

Figure 1
圖一

(a) On the answer sheet, draw all the lines of symmetry of Figure 1. [2 marks]

(b) If the perimeter of Figure 2 is 24cm shorter than that of Figure 1, what is the perimeter of Figure 2? (Give the answer only) [2 marks]

33. 夢珊用 16 個大小相同的等邊三角形組成圖一及圖二的形狀。

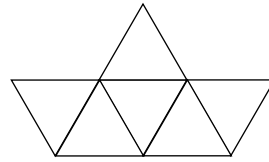

Figure 2
圖二

(a) 在答題紙上，畫出圖一的所有對稱軸。 [2 分]

(b) 如果圖二的周界比圖一的周界短 24 cm，圖二的周界是多少？(只須寫出答案) [2 分]

34. Mr Wong planned to have the lunch buffet with his wife and two sons. The special offers from Sunny Restaurant and Delicious Restaurant were as follows.

Sunny Restaurant
陽光餐廳

\$225 each

Half price will be offered to the fourth person

每位\$225

第四位可獲半價優惠

34. 黃先生計劃與妻子及兩位兒子去吃自助午餐。陽光餐廳和美味餐廳有以下優惠。

Delicious Restaurant
美味餐廳

\$225 each

20% discount will be offered when using credit card for payment

每位\$225

以信用卡付款，可獲八折優惠

(a) If Mr Wong's family had the lunch buffet in Sunny Restaurant, how much should the four of them pay in total?
[4 marks]

(b) If Mr Wong's would pay by credit card, at which restaurant should they have the lunch buffet so as to pay less? Explain.
[4 marks]

(a) 如果黃先生一家在陽光餐廳吃自助午餐，他們四人共須付多少？ [4分]

(b) 如果黃先生將會以信用卡付費，他們應該在哪一間餐廳吃自助午餐才可付較少？試解釋。 [4分]

35. There are 640 students in a school. $\frac{3}{8}$ of the students go to school by bus, $\frac{2}{5}$ of the students go to school by private car, and the remaining students go to school on foot.

(a) What is the fraction of the students going to school on foot? (Give the answer only)

[2 marks]

(b) If there are 288 girls in the school, what percentage of students are boys? (Give the answer only) [2 marks]

(c) Tim's home is 1.8km away from the school. It took him 25 minutes to walk home yesterday. What was Tim's average walking speed? (Give the answer only) [2 marks]

35. 學校有學生 640 人。其中 $\frac{3}{8}$ 的學生乘搭巴士上學， $\frac{2}{5}$ 的學生乘搭私家車上學，剩下的學生步行上學。

(a) 步行上學的學生人數佔全校學生的幾分之幾？(只須寫出答案) [2 分]

(b) 如果學校女生有 288 人，男生人數佔全校人數的百分之幾？(只須寫出答案) [2 分]

(c) 偉建家距離學校 1.8km，昨天他步行回家用了 25 分鐘，偉建步行的平均速率是多少？(只須寫出答案) [2 分]

36. The following is the floor plan of the area around a school.

36. 以下是某學校周圍的平面圖。



(a) The Hospital is in the south of the School. Which direction is the School from the Cinema? (Give the answer only) [2 marks]

(a) 醫院在學校的南方。學校在電影院的哪一方？(只須寫出答案) [2分]

(b) During a big sale in the Supermarket, all juice was sold at 'Buy 2 and get 1 free'. Ivy bought 3 bottles of juice. Each bottle of juice cost \$12 originally. By how much was each bottle of juice cheaper on average? [4 marks]

(b) 超級市場正進行大減價，所有果汁買 2 送 1。子瑩買了 3 瓶果汁，每瓶原價是 \$12，平均每瓶果汁便宜了多少？ [4分]

(c) Karen and 3 classmates went to the Cinema to watch a film. The price is \$35.5 per ticket. How much should they pay total? (Give the answer only) [2 marks]

(c) 凱琳和 3 位同學到電影院看電影。電影票每張 \$35.5，她們共須付多少？(只須寫出答案) [2分]

End of Test Paper

測驗卷完