

HONG KONG ATTAINMENT TEST
香港學科測驗

Mathematics 數學

Primary 5 五年級

Mock Paper of the Latest Question Types
最新題型增值卷

題號	學習重點	範疇
1	多位數(5上)	數
2	整數乘法(4上)	
3	整數除法(4上)	
4	整數四則混合計算(4下)	
5	公倍數(4上)	
6	異分母分數加法(5上)	
7	同分母分數減法(4下)	
8	小數乘法(5下)	
9	分數乘法(5上)	
10	分數除法(5下)	
11	小數的認識(4下)	
12	分數加減混合計算(5上)	
13	分數四則混合計算(5下)	
14	分數的大小比較(5上)	
15	分數四則混合計算(5下)	
16	圖形的拼砌(4上)	圖形與空間
17	八個方向(4上)	
18	圖形的分割(4上)	
19	立體圖形的特性(5下)	
20	圓的認識(5下)	
21	周界(4下)	度量
22	周界(4下)	

題號	學習重點	範疇
23	體積(5下)	度量
24	面積(4下)	
25	面積(5上)	
26	面積(5上)	
27	體積(5下)	
28	象形圖(2下), 分數除法(5下)	數據處理
29	複合棒形圖(5上)	代數
30	簡易方程(5下)	
31(a)	代數式(5上)	代數
31(b)	簡易方程(5下)	
32(a)	棒形圖(4下)	數據處理
32(b)	棒形圖(4下)	
33(a)	面積(5上)	度量
33(b)	面積(5上)	
34(a)	分數除法(5下)	數
34(b)	整數四則混合計算(4下)	
34(c)	分數四則混合計算(5下)	
35(a)	整數除法(4上)	圖形與空間
35(b)	整除性(4上)	
35(c)	八個方向(4上)	
36(a)	摺紙圖樣(5下)	度量
36(b)	體積(5下)	
36(c)	分數除法(5下)	

Time allowed for the test: 50 minutes

測驗時間：50 分鐘

Instructions:

1. This test contains two sections:

Section A: Questions 1-30

Section B: Questions 31-36

2. Answer ALL questions.

3. Write your answers on the answer sheet.

4. Write your name, class and class number on the answer sheet.

5. You may do your rough work in the blank space of this test booklet and there is no need to rub it out after the test.

6. You can use a pencil or a black/blue ball pen to answer the questions.

7. The use of calculator is not allowed.

學生須知：

1. 本測驗卷共有兩部分：

甲部：第 1 至第 30 題

乙部：第 31 至第 36 題

2. 全部題目均須作答。

3. 把答案寫在答題紙上。

4. 在答題紙上填寫學生姓名、班別及學號。

5. 學生可利用本測驗卷的空白部分做算草，測驗完畢後無須將算草擦去。

6. 學生可以用鉛筆或黑/藍色圓珠筆作答。

7. 不准使用計算機。

Note:
Not all diagrams are drawn to scale.

注意：
部分附圖不依比例繪畫。

SECTION A (60 marks)

Choose the correct answer. You only need to write down the letter preceding the selected answer.

甲部 (60 分)

選出正確的答案。學生只須填上所選答案前的英文字母。

1. The actual number of users of the website E is 286 149. When corrected to the nearest ten thousand, both the number of users of website E and website F are the same. Which of the following numbers may be the actual number of users of website F?

- A. 279 862 Corrected 286 149 to the nearest ten thousand is 290 000.
B. 284 843 Corrected to the nearest ten thousand
 C. 293 017 A. 280 000
B. 280 000
C. 290 000
D. 297 862
D. 297 862 D. 300 000

1. 網站 E 的實際用戶人數是 286 149。當取近似值至萬位，網站 E 和網站 F 的用戶人數一樣。下列哪一個數可能是網站 F 實際的用戶人數？

- A. 279 862 286 149 取近似值至萬位是 290 000。
B. 284 843 取近似值至萬位
 C. 293 017 A. 280 000
B. 280 000
C. 290 000
D. 300 000
D. 297 862

2. The charity needed to distribute 18 boxes of apples. If each box had 12 packs of apples and each pack had 9 apples, how many apples did the charity distribute in total?

- A. 162 There are:
 $18 \times 12 \times 9$
 $= 1944$ (apples)
B. 216
C. 1494
 D. 1944

2. 機構須派發 18 箱蘋果。如果每箱蘋果有 12 袋，每袋蘋果有 9 個，機構共派發蘋果多少個？

- A. 162 共派發蘋果：
 $18 \times 12 \times 9$
 $= 1944$ (個)
B. 216
C. 1494
 D. 1944

3. $\boxed{2}\boxed{1}\boxed{\star}$ is a 3-digit number.

When it is divided by 18, the remainder is 16. Which of the following is $\boxed{\star}$?

A. $\boxed{2}$

B. $\boxed{4}$

C. $\boxed{6}$

D. $\boxed{8}$

A. $212 \div 18 = 11 \dots 14$

B. $214 \div 18 = 11 \dots 16$

C. $216 \div 18 = 12$

D. $218 \div 18 = 12 \dots 2$

3. $\boxed{2}\boxed{1}\boxed{\star}$ 是一個三位數。當它除以 18，餘數是 16，下列哪個是

$\boxed{\star}$?

A. $\boxed{2}$

B. $\boxed{4}$

C. $\boxed{6}$

D. $\boxed{8}$

4. A box of 16 ballpoint pens sells for \$240. The average price of each ballpoint pen is more expensive than that of each pencil by \$5. To buy four dozen pencils, how much should be paid?

A. \$720 The average price of each pencil is:
 $240 \div 16 - 5 = \$10$

B. \$640 There are
 $10 \times 12 \times 4$
 $= \$480$

C. \$480

D. \$360

4. 一盒原子筆有 16 枝，售價是 \$240。每枝原子筆的平均售價較每枝鉛筆的貴 \$5。買四打鉛筆須付多少？

A. \$720 每枝鉛筆的平均售價是：
 $240 \div 16 - 5 = \$10$

B. \$640 須付：
 $10 \times 12 \times 4$
 $= \$480$

C. \$480

D. \$360

7. If $\frac{4\Box - \star}{5} = 0$, then $4\Box - \star = ?$

A. 4 $\frac{4\Box - \star}{5} = \frac{4\Box - \star}{5} = 0, 0 = \frac{0}{5}$

B. 3 $\frac{4\Box - \star}{5} = \frac{0}{5}$

C. 1 So $4\Box - \star = 0$

D. 0

7. 如果 $\frac{4\Box - \star}{5} = 0$ ，那麼，

$4\Box - \star = ?$

A. 4 $\frac{4\Box - \star}{5} = \frac{4\Box - \star}{5} = 0, 0 = \frac{0}{5}$

B. 3 $\frac{4\Box - \star}{5} = \frac{0}{5}$

C. 1 所以 $4\Box - \star = 0$

D. 0

8. Which of the following has the largest value?

A. 4.2×1.6 Compare options A and C, eliminate C.

B. 3.7×1.8 Compare options B and D, eliminate D.

C. 0.42×1.6 A. $4.2 \times 1.6 = 6.72$
B. $3.7 \times 1.8 = 6.66$

D. 0.37×1.8

8. 下列哪一項的值最大？

A. 4.2×1.6 比較選項 A 和 C，
剔除 C。

B. 3.7×1.8 比較選項 B 和 D，
剔除 D。

C. 0.42×1.6 A. $4.2 \times 1.6 = 6.72$
B. $3.7 \times 1.8 = 6.66$

D. 0.37×1.8

9. There are 96 buttons in each pack, $\frac{7}{12}$ of the buttons are red. How many red buttons are there in total if there are 14 packs?

A. 40 $96 \times \frac{7}{12} \times 14$

B. 56 $= 784$ There are 784 red buttons in total.

C. 560

D. 784

9. 每包鈕扣有 96 粒，其中 $\frac{7}{12}$ 是紅色的。如果現有 14 包鈕扣，共有紅色鈕扣多少粒？

A. 40 $96 \times \frac{7}{12} \times 14$

B. 56 $= 784$ 共有紅色鈕扣 784 粒。

C. 560

D. 784

10. Each kettle can hold $4\frac{3}{4}$ L of herbal tea. How many kettles can be fully filled if there are 114L of herbal tea?

A. 784 There are:

B. 75 $114 \div 4\frac{3}{4}$

C. 24 = 24

D. 12

10. 每個水壺可以盛載 $4\frac{3}{4}$ 升涼茶。如果現有 114 升涼茶，可以盛滿水壺多少個？

A. 784 可以盛滿水壺：

B. 75 $114 \div 4\frac{3}{4}$

C. 24 = 24 (個)

D. 12

11. The correct answer of a mathematics question was 2109.457, but Carmen wrongly exchanged the hundredth digit and the tenth digit. Which of the following numbers was Carmen's answer?

A. 2019.457 In the number 2109.457, the hundredth digit is '5' and the tenth digit is '4'.

B. 2109.547 So Carmen's answer was 2109.547.

C. 2109.754

D. 2159.407

11. 某數學題的正確答案是 2109.457，但是家雯卻誤把百分位和十分位的數字互換了。以下哪一個是家雯的答案？

A. 2019.457 在 2109.457 這個數中，百分位數字是「5」，

B. 2109.547 十分位數字是「4」。所以家雯的答案是：

C. 2109.754

D. 2159.407

12. There are $31\frac{3}{4}$ kg of peanuts in the nut shop. The peanuts are $5\frac{2}{5}$ kg heavier than the walnuts. What is the total weight of peanuts and walnuts?

- A. $68\frac{9}{10}$ kg The total weight of peanuts and walnuts is
 $31\frac{3}{4} + 31\frac{3}{4} - 5\frac{2}{5}$
 $= 58\frac{1}{10}$ (kg)
- C.** $58\frac{1}{10}$ kg
- D. $57\frac{1}{10}$ kg

12. 堅果店有花生 $31\frac{3}{4}$ kg，比核桃多 $5\frac{2}{5}$ kg。堅果店內共有花生和核桃多少？

- A. $68\frac{9}{10}$ kg 共重
 $31\frac{3}{4} + 31\frac{3}{4} - 5\frac{2}{5}$
 $= 58\frac{1}{10}$ (kg)
- C.** $58\frac{1}{10}$ kg
- D. $57\frac{1}{10}$ kg



Each
 $\$12\frac{1}{2}$
 每個

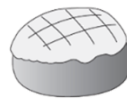

Each
 $\$8\frac{3}{5}$
 每個

13. There are 2 croissants and 1 pineapple bun in a discount package, the price is \$30. If the same number of croissants and pineapple bun are bought, how much can be saved by buying the discount package?

- A.** $\$3\frac{3}{5}$ It can be saved:
 $12\frac{1}{2} \times 2 + 8\frac{3}{5} - 30$
 $= \$3\frac{3}{5}$
- B. $\$3\frac{7}{10}$
- C. $\$4\frac{3}{10}$
- D. $\$4\frac{3}{5}$

13. 優惠套裝內有 2 個牛角包和 1 個菠蘿包，售價是 \$30。如果買相同數量的牛角包和菠蘿包，買優惠套裝可以節省多少？

- A.** $\$3\frac{3}{5}$ 可以節省：
 $12\frac{1}{2} \times 2 + 8\frac{3}{5} - 30$
 $= \$3\frac{3}{5}$
- B. $\$3\frac{7}{10}$
- C. $\$4\frac{3}{10}$
- D. $\$4\frac{3}{5}$

14. Arrange the following three numbers from the smallest to the largest:

$$\frac{32}{9}, 4, 3\frac{7}{12}$$

A. $\frac{32}{9} < 4 < 3\frac{7}{12}$ $\frac{32}{9} = 3\frac{5}{9} = 3\frac{20}{36}$

B. $\frac{32}{9} < 3\frac{7}{12} < 4$ $3\frac{7}{12} = 3\frac{21}{36}$
 $\frac{32}{9} < 3\frac{7}{12} < 4$

C. $3\frac{7}{12} < \frac{32}{9} < 4$

D. $4 < 3\frac{7}{12} < \frac{32}{9}$

14. 把以下三個數由小至大排列：

$$\frac{32}{9}, 4, 3\frac{7}{12}$$

A. $\frac{32}{9} < 4 < 3\frac{7}{12}$

B. $\frac{32}{9} < 3\frac{7}{12} < 4$

C. $3\frac{7}{12} < \frac{32}{9} < 4$

D. $4 < 3\frac{7}{12} < \frac{32}{9}$

15. The company has 105 employees, 30 of them were British and $\frac{3}{10}$ of the remaining were Germans. What was the fraction of Germans to all employees?

A. $\frac{3}{14}$ The fraction was:
 $(1 - \frac{30}{105}) \times \frac{3}{10}$

B. $\frac{7}{10} = \frac{3}{14}$

C. $\frac{11}{14}$

D. $\frac{9}{10}$

15. 公司有 105 名員工，其中 30 人是英國人，餘下的 $\frac{3}{10}$ 是德國人。德國人佔全部員工的幾分之幾？

A. $\frac{3}{14}$ 德國人佔全部員工的：
 $(1 - \frac{30}{105}) \times \frac{3}{10}$

B. $\frac{7}{10} = \frac{3}{14}$

C. $\frac{11}{14}$

D. $\frac{9}{10}$

16. Which of the following descriptions about isosceles right-angled triangles is incorrect?

- A. A square can be formed by fitting two isosceles right-angled triangles of the same size.
- B. A trapezium can be formed by fitting three isosceles right-angled triangles of the same size.
- C. A triangle can be formed by fitting four isosceles right-angled triangles of the same size.
- D.** A parallelogram can be formed by fitting five isosceles right-angled triangles of the same size.

16. 下列哪一項有關等腰直角三角形的描述是錯誤的？

- A. 兩個大小相同的等腰直角三角形可以拼出一個正方形。
- B. 三個大小相同的等腰直角三角形可以拼出一個梯形。
- C. 四個大小相同的等腰直角三角形可以拼出一個三角形。
- D.** 五個大小相同的等腰直角三角形可以拼出一個平行四邊形。

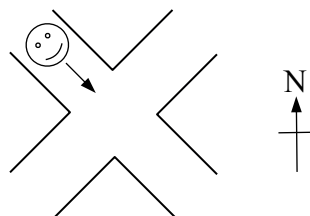
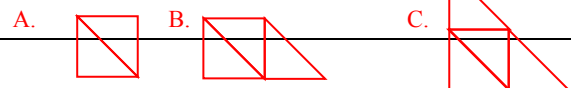

17. In the above figure, when Ben arrives at the junction, he will turn left and walk on. In which direction will he walk then?

- A. south
- B. north
- C. southwest
- D.** northeast

17. 上圖中，當文彬步行至分岔路口時，他會轉左繼續步行，即他向哪一方繼續步行？

- A. 南
- B. 北
- C. 西南
- D.** 東北

18. Anne drew a straight line on a rectangle paper and two trapeziums were obtained. Which descriptions in the following must be correct?

- I. There are two right angles in each of the trapeziums.
- II. The perimeter of two trapeziums were equal.
- III. There was an obtuse angle in each of the trapeziums.

- A. I and II only
- B. I and III only**
- C. II and III only
- D. I, II and III

18. 佳敏在一張長方形的紙上畫了一條直線，得出兩個梯形。下列哪些描述必定正確？

- I. 兩個梯形各有兩個直角。
- II. 兩個梯形的周界相等。
- III. 兩個梯形各有一隻鈍角。

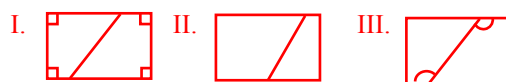

- A. 只有 I 及 II
- B. 只有 I 及 III**
- C. 只有 II 及 III
- D. I, II 及 III

19. By using all plastic sticks and plastic beads of the following two 3-D shapes, how many triangular prisms can be formed at most?

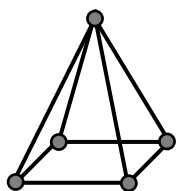

- A. 5 A triangular prism has 9 edges and 6 vertices. There are 23 plastic sticks and 15 plastic beads.
- B. 4 $23 \div 10 = 2 \dots 3$
 $15 \div 6 = 2 \dots 3$
- C. 3 2 triangular prisms can be formed at most.
- D. 2**

19. 用以下兩個立體圖形的所有膠棒和膠珠，最多可以組成多少個三角柱？

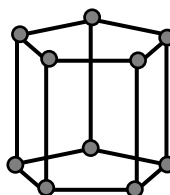

- A. 5 三角柱有 9 條稜和 6 個頂點。共有 23 枝膠棒和 15 粒膠珠。
 $23 \div 10 = 2(\text{個}) \dots 3(\text{枝})$
- B. 4 $15 \div 6 = 2(\text{個}) \dots 3(\text{粒})$
最多可組成 2 個三角柱。
- C. 3
- D. 2**

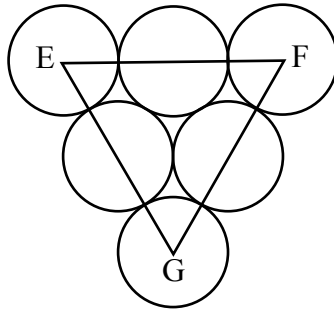

20. The above figure is formed by six circles of the same size and one triangle. E, F and G are centres. If the diameter of each circle is 8cm, what is the perimeter of the triangle?

- A. 16cm
- B. 24cm
- C. 48cm**
- D. 96cm

The perimeter of the triangle is equal to the length of 12 radii.
The perimeter of the triangle is:
 $8 \div 2 \times 12$
 $= 48(\text{cm})$

20. 上圖由六個大小相同的圓和一個三角形組成。E、F 和 G 是圓心。如果每個圓的直徑是 8cm，三角形的周界是多少？

- A. 16cm
- B. 24cm
- C. 48cm**
- D. 96cm

三角形的周界等於 12 條半徑的長度。
三角形的周界是：
 $8 \div 2 \times 12$
 $= 48(\text{cm})$

Figure 1

圖一

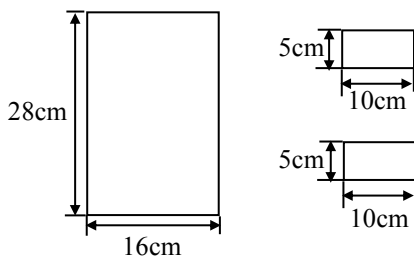
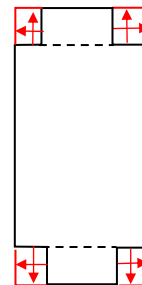
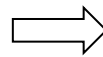

Figure 2

圖二



21. Figure 2 is formed by fitting the three rectangle shown in Figure 1. What is its perimeter?

- A. 108cm**
- B. 114cm
- C. 136cm
- D. 148cm

Its perimeter is:
 $(28 + 5 + 5 + 16) \times 2$
 $= 108(\text{cm})$

21. 圖二是由圖一所示的三個長方形拼砌而成，它的周界是多少？

- A. 108cm**
- B. 114cm
- C. 136cm
- D. 148cm

它的周界是：
 $(28 + 5 + 5 + 16) \times 2$
 $= 108(\text{cm})$

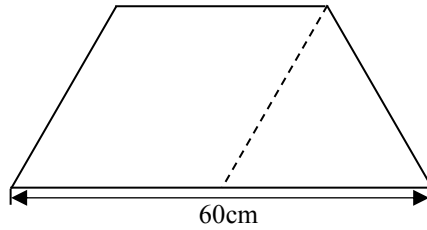

22. A carpet is formed by a rhombus and an equilateral triangle, as shown above. what is its perimeter?

- A. 120cm The side of the rhombus is equal to the side of the equilateral triangle.
 B. 140cm The side of the rhombus and the side of the equilateral triangle is:
 $60 \div 2 = 30(\text{cm})$
C. 150cm Its perimeter is:
 $60 + 30 \times 3 = 150(\text{cm})$
 D. 180cm

22. 一張地毯由一個菱形和一個等邊三角形組成，如上圖所示。它的周界是多少？

- A. 120cm 菱形的邊長和等邊三角形的邊長相等。
 B. 140cm 菱形的邊長和等邊三角形的邊長是：
 $60 \div 2 = 30(\text{cm})$
 它的周界是：
 $60 + 30 \times 3 = 150(\text{cm})$
C. 150cm
 D. 180cm

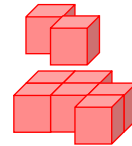
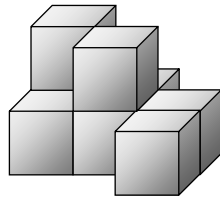

23. The above solid is formed by cubes with side 3cm. What is the volume of the whole solid?

- A. 8cm^3 The volume of the whole solid is:
 $3 \times 3 \times 3 \times 8 = 216(\text{cm}^3)$
 B. 64cm^3
 C. 162cm^3
D. 216cm^3

23. 以上的立體由多個邊長 3cm 的正方體組成。整個立體的體積是多少？

- A. 8cm^3 整個立體的體積是：
 $3 \times 3 \times 3 \times 8 = 216(\text{cm}^3)$
 B. 64cm^3
 C. 162cm^3
D. 216cm^3

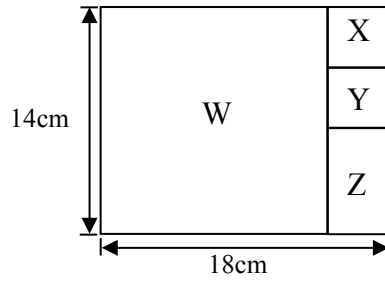

24. In the above figure, W, X and Y are squares. Find the area of Z.

- A. 24cm^2 The sides of X and Y are:
 $18 - 14 = 4(\text{cm})$
- B. 32cm^2 The area of Z is:
 $(14 - 4 - 4) \times 4 = 24(\text{cm}^2)$
- C. 124cm^2
- D. 252cm^2

24. 在上圖，W，X和Y是正方形。求Z的面積。

- A. 24cm^2 X和Y的邊長是： $18 - 14 = 4(\text{cm})$
Z的面積是：
 $(14 - 4 - 4) \times 4 = 24(\text{cm}^2)$
- B. 32cm^2
- C. 124cm^2
- D. 252cm^2

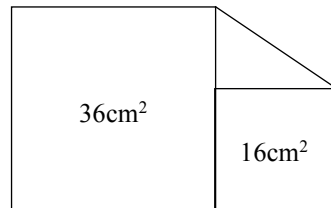

25. The above figure is formed by two squares and a triangle. What is the area of the triangle?

- A. 8cm^2 $16 = 4 \times 4$, $36 = 6 \times 6$
- B. 12cm^2 The base of the triangle is 4cm.
The height of the triangle is 6cm.
The area of the triangle is:
 $4 \times 6 \div 2 = 12(\text{cm}^2)$
- C. 16cm^2
- D. 32cm^2

25. 上圖是由一個兩個正方形和一個三角形組成。三角形的面積是多少？

- A. 8cm^2 $16 = 4 \times 4$, $36 = 6 \times 6$
三角形的底是 4cm，
高是 6cm。
- B. 12cm^2 三角形的面積是：
 $4 \times 6 \div 2 = 12(\text{cm}^2)$
- C. 16cm^2
- D. 32cm^2

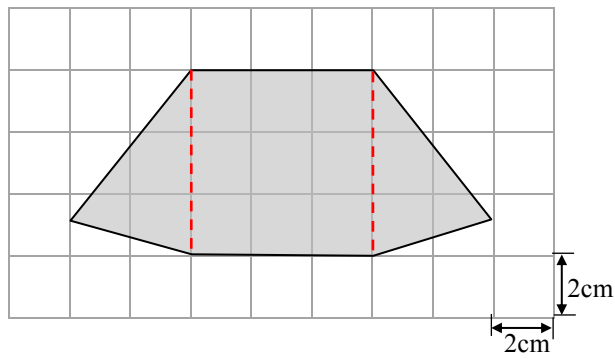

26. In the above figure, what is the area of the shaded part?

- A. 15cm^2 The area of the shaded part is:
 $(2 \times 3) \times (2 \times 3) + (2 \times 3) \times (2 \times 2)$
 $\div 2 \times 2$
- B. $30\text{cm}^2 = 60(\text{cm}^2)$
- C. 45cm^2
- D. 60cm^2**

26. 上圖陰影部分的面積是多少？

- A. 15cm^2 陰影部分的面積是：
 $(2 \times 3) \times (2 \times 3) + (2 \times 3) \times (2 \times 2)$
 $\div 2 \times 2$
- B. $30\text{cm}^2 = 60(\text{cm}^2)$
- C. 45cm^2
- D. 60cm^2**

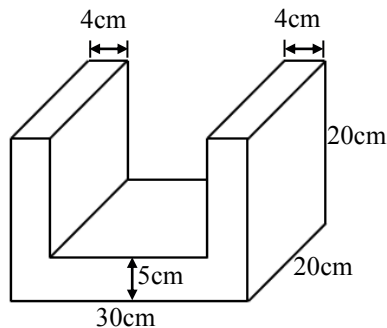

27. What is the volume of the above solid?

- A. 4200cm^3 The volume is:
 $30 \times 20 \times 20 - (30 - 4 - 4)$
 $\times 20 \times (20 - 5)$
 $= 5400(\text{cm}^3)$
- B. 4500cm^3
- C. 5400cm^3**
- D. 6000cm^3

27. 上圖立體的體積是多少？

- A. 4200cm^3 體積是：
 $30 \times 20 \times 20 - (30 - 4 - 4)$
 $\times 20 \times (20 - 5)$
 $= 5400(\text{cm}^3)$
- B. 4500cm^3
- C. 5400cm^3**
- D. 6000cm^3

Number of Goldfish in the Tank

魚缸裏金魚的數量

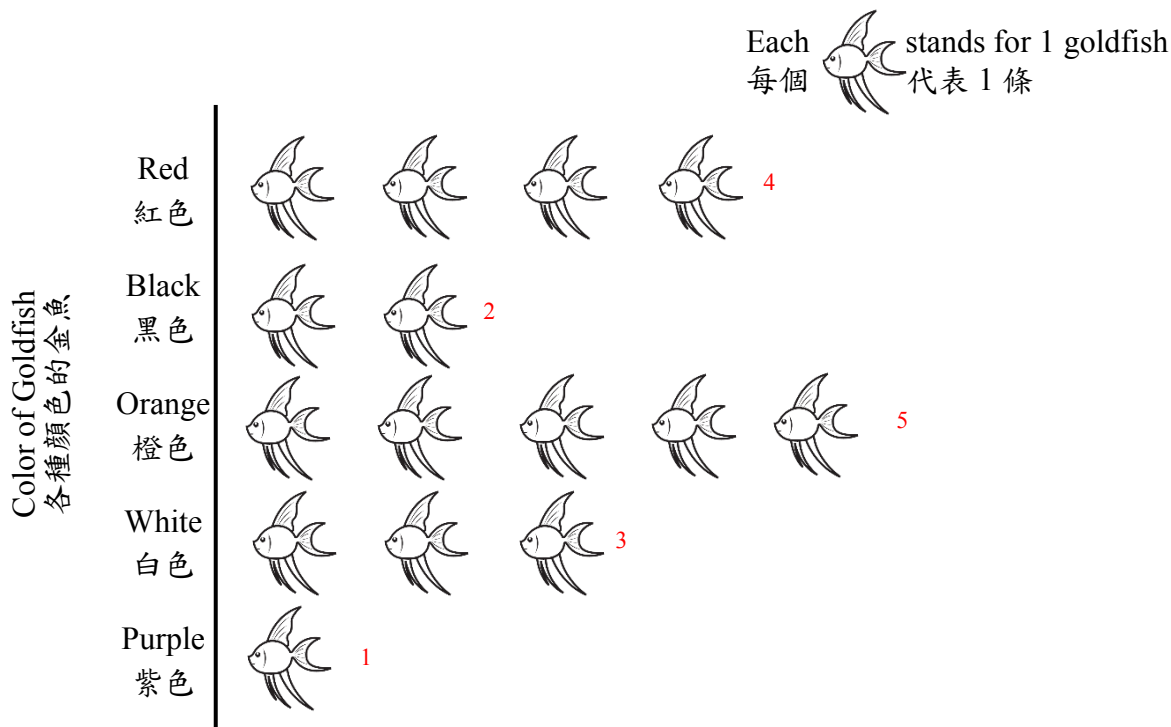

28. According to the above graph, what was the fraction of the number of black goldfish and white goldfish to the total goldfishes?

- A. $\frac{1}{15}$ The fraction is: $\frac{2+3}{4+2+5+3+1} = \frac{1}{3}$
- B. $\frac{2}{15}$
- C. $\frac{1}{5}$
- D. $\frac{1}{3}$**

28. 根據上圖，黑色金魚和白色金魚的數量佔全部金魚數量的幾分之幾？

- A. $\frac{1}{15}$ 佔全部金魚數量的： $\frac{2+3}{4+2+5+3+1} = \frac{1}{3}$
- B. $\frac{2}{15}$
- C. $\frac{1}{5}$
- D. $\frac{1}{3}$**

Number of Books in Four Book Corners

四個圖書角的圖書數量

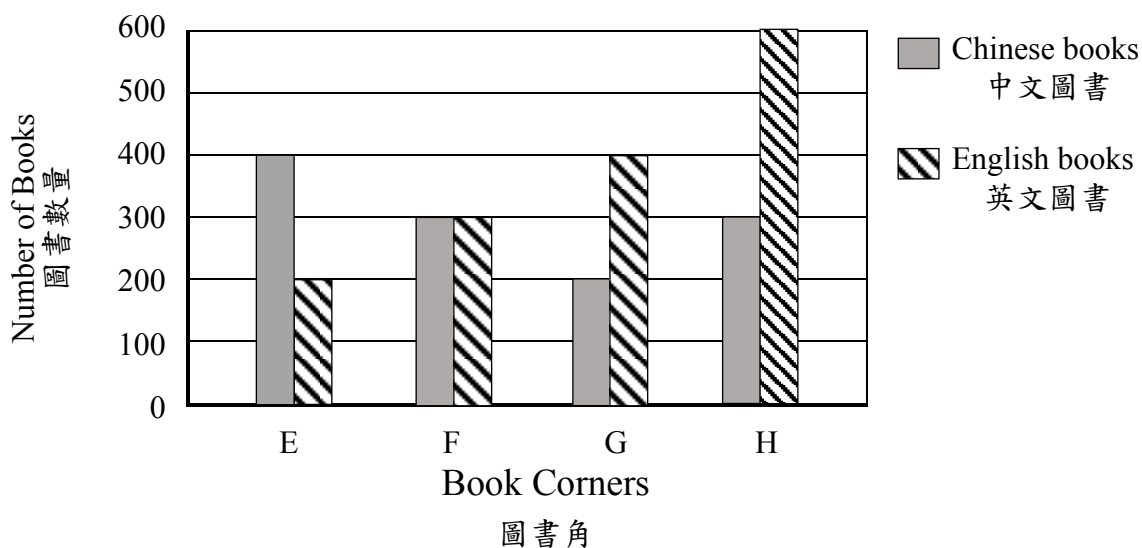

29. According to the above graph, which description in the following is correct?

- I. The total number of English books in the four book corners is 1500.
- II. The difference of the number of books between Book Corner F and Book Corner G is 100.
- III. The number of Chinese books in Book Corner H is $\frac{1}{3}$ of the total number of books in Book Corner H.

A. I and II only

B. I and III only

C. II and III only

D. I, II and III only

I. The total number is:
 $200 + 300 + 400 + 600 = 1500$

II. The difference is:
 $(300 + 300) - (200 + 400) = 0$

III. The fraction is:
 $\frac{300}{300 + 600} = \frac{1}{3}$

29. 根據上圖，下列哪些描述是正確的？

- I. 四個圖書角英文圖書的總數量是 1500 本。
- II. 圖書角 F 和 G 的圖書數量相差 100 本。
- III. 圖書角 H 的中文圖書數量佔圖書角 H 圖書總數量的 $\frac{1}{3}$ 。

III. 估圖書角 H 圖書總數量的：
 $\frac{300}{300 + 600} = \frac{1}{3}$

A. 只有 I 及 II

B. 只有 I 及 III

C. 只有 II 及 III

D. I、II 及 III

30. If $\frac{P}{7} = 8$, what is the value of $2P$?

A. 56

B. 58

C. 112

D. 146

$$\begin{aligned}\frac{P}{7} &= 8 \\ \frac{P}{7} \times 7 &= 8 \times 7 \\ P &= 56 \\ 2P &= 2 \times 56 = 112\end{aligned}$$

30. 如果 $\frac{P}{7} = 8$ ，那麼 $2P$ 的值是多少？

A. 56

B. 58

C. 112

D. 146

End of Section A
甲部完

SECTION B (40 marks)

Working steps must be shown in answering questions in this section unless specified otherwise.

乙部 (40 分)

除特別指明外，在回答本部分的問題時，須列出計算步驟。

31. The following table shows the visitors to the jewelry show in the past two days.

31. 下表顯示珠寶展過去兩天入場的人數。

Visitors to the jewelry show in the past two days

珠寶展過去兩天入場的人數

	The first day 第一天	The second day 第二天
Morning 上午	w	128
Afternoon 下午	201	154

(a) What was the total number of visitors to the jewelry show in the first day? (Give the answer only and express the answer in terms of w) $(w+201)$ [2 marks]

(a) 珠寶展第一天的總入場人數是多少？(只須寫出答案，答案以 w 表示) [2 分]

$(w+201)$

(b) If the total number of visitors in the first day was equal to 2 times of the total number of visitors in the second day, what was the number of visitors on the first day morning? (Use equation to solve the problem and show your working steps) [4 marks]

(b) 如果第一天的總入場人數是第二天的總入場人數的 2 倍，第一天上午的入場人數是多少？(須用方程列式計算，並展示步驟) [4 分]

$w+201 = (128+154) \times 2$

$w = 363$

第一天上午的入場人數是 363 人。

$w+201 = (128+154) \times 2$

$w = 363$

The number of visitors on the first day morning was 363.

Sales of Fans in an Electronics Store in the Past Six Months

某電器店過去六個月的風扇銷量

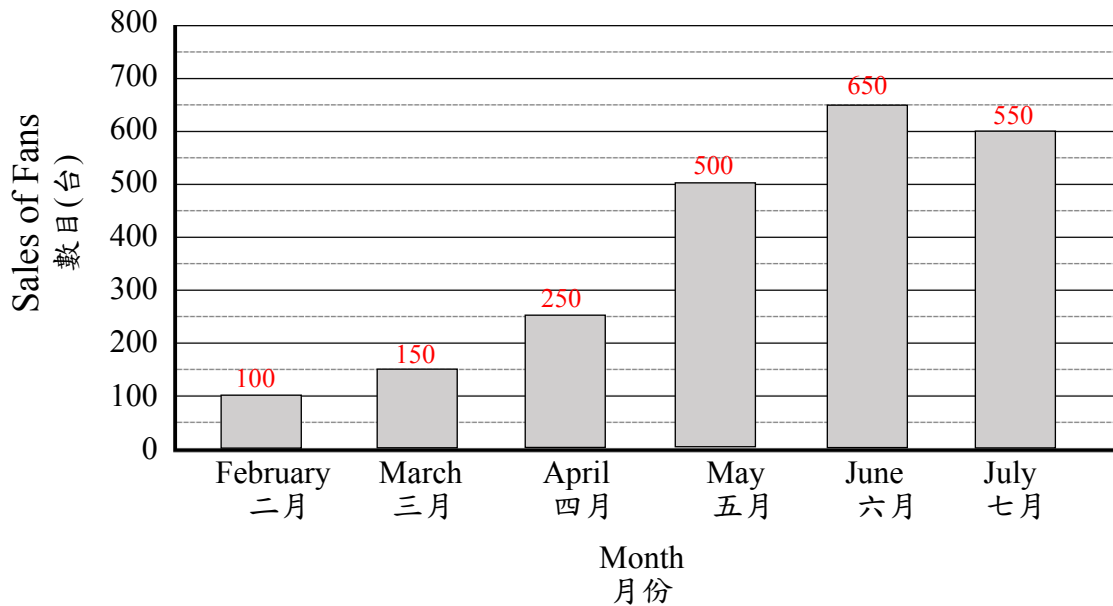

32. (a) Comparing the sales of fans by month, what is the difference between the greatest and the smallest sales of fans? (Give the answer only) [2 marks]

550
The difference is: $650 - 100 = 550$

(b) When the difference between the sales of fans in two months was greater than 200, it indicated that there was a significant change in temperature. According to the above graph, in which two consecutive months was there a significant change in the sales of fans? Explain by using the data.

The sales of fans in April is 250, the sales of fans in May is 500, $500 - 250 = 250$, $250 > 200$ (Accept any other reasonable explanation)

April, May

32. (a) 試比較風扇的銷量最多的月份與最少的月份，風扇的銷量相差多少台？(只須寫出答案) [2分]

550
風扇的銷量相差： $650 - 100 = 550$ (台)

(b) 當兩個相連月份的風扇銷量相差大於 200 台，則表示氣溫有明顯的變化。根據上圖，試用數據解釋在哪兩個相連月份的氣溫有明顯變化。 [2分]

四月風扇的銷量是 250 台，五月風扇的銷量是 500 台， $500 - 250 = 250$ ， $250 > 200$ (其他合理解釋也可接受)
四，五

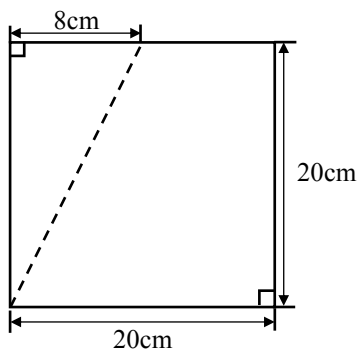

Figure 1

圖一

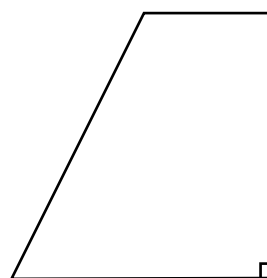

Figure 2

圖二

33. Sammi is making a greeting card. After she cuts along the dotted line in Figure 1 to remove a triangle, a trapezium is obtained as shown in Figure 2.

(a) What is the area of the trapezium?

The area of the trapezium is
 $(20 - 8 + 20) \times 20 \div 2$ [4 marks]
 $= 320(\text{cm}^2)$

(b) Sammi used the trapezium of Figure 2 to make two greeting cards as shown below. She believes that the areas of the shaded parts in the two greeting cards are the same. Do you agree? Explain.

The shaded parts are triangles with base of 20 cm and height of 20 cm. The areas both are: [4 marks]

$$20 \times 20 \div 2 = 200(\text{cm}^2)$$

(Accept any other reasonable explanation) agree

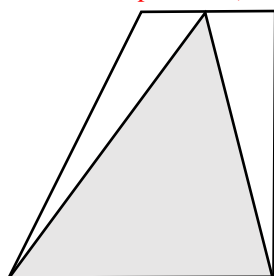

Greeting card 1

賀卡一

33. 思敏正在製作一張賀卡。她沿着虛線剪去一個三角形後，得出圖二所示的梯形。

(a) 梯形的面積是多少？ [4分]

梯形的面積是：
 $(20 - 8 + 20) \times 20 \div 2$
 $= 320(\text{cm}^2)$

(b) 下圖顯示思敏利用圖二梯形所設計的兩張賀卡，她認為兩張賀卡的陰影部分的面積一樣。你同意嗎？試解釋。 [4分]

陰影部分都是底為20cm、高為20cm的三角形，面積都是： $20 \times 20 \div 2 = 200(\text{cm}^2)$

(其他合理解釋也可接受)

同意

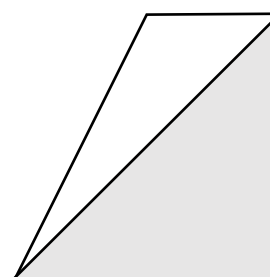

Greeting card 2

賀卡二

34. The following table shows the single journey fee of sightseeing bus and boat.

34. 下表顯示觀光巴士和觀光船的單程費用。

	Sightseeing bus 觀光巴士	Sightseeing boat 觀光船
Adult 成人	$\$41\frac{4}{5}$	\$200
Child (aged 12 or below) 小童(12歲或以下)	$\$20\frac{9}{10}$	\$120

(a) What is the fraction of the single journey fee for a child to take the sightseeing boat to that of an adult? (Give the answer only)

$\frac{3}{5}$ [2 marks]

The fraction is: $120 \div 200 = \frac{3}{5}$

(b) Ms Wong went to take a sightseeing bus with 4 adults and a child together. How much did she pay in total? [4 marks]

She paid
 $41\frac{4}{5} \times 5 + 20\frac{9}{10}$
 $= \$229\frac{9}{10}$

(c) Mr and Mrs Chan went to take a sightseeing boat with 3 daughters aged below 12. How much did they pay in total? (Give the answer only)

760
 They paid:
 $200 \times 2 + 120 \times 3 = \760 [2 marks]

(a) 小童乘坐觀光船的單程費用是成人的幾分之幾？(只須寫出答案) $\frac{3}{5}$ [2分]

是成人的： $120 \div 200 = \frac{3}{5}$

(b) 王小姐帶同4名成人和1名小童乘坐觀光巴士。她共付了多少？ [4分]

她共付了
 $41\frac{4}{5} \times 5 + 20\frac{9}{10}$
 $= \$229\frac{9}{10}$

(c) 陳先生和陳太太帶同3名小於12歲的女兒乘坐觀光船。他們共付了多少？(只須寫出答案) [2分]

760
 他們共付了：
 $200 \times 2 + 120 \times 3 = \760

35. The daily rent for a booth at the flea market is \$90.

(a) Eric has \$285. How many days could he rent a booth at most?

3 (Give the answer only) [2 marks]

$$285 \div 90 = 3 \cdots 15$$

He could rent a booth for 3 days at most.

(b) The serial numbers of Eric's booth was a 2-digit number. The number was a multiple of 16 and divisible by 10. What was the serial number of that booth?

(Give the answer only)

[2 marks]

80

The multiples of 16 are 16, 32, 48, 64, 80, 96, 110.....

An integer whose units digit is 0 is divisible by 10.

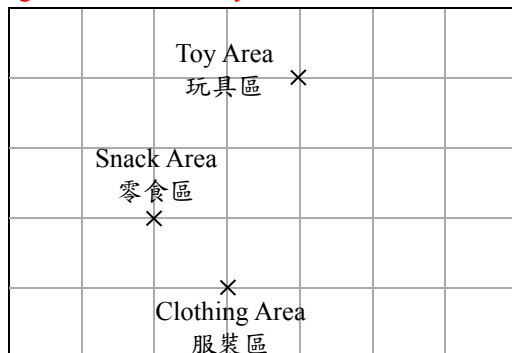

(c) According to the above floor plan of the flea market, the Clothing Area was in the southwest of the Snack Area. If Eric wanted to go to the Toy Area from the snack area, in which direction should he go?

(Give the answer only)

southeast

[2 marks]

35. 跳蚤市場一個攤位每天的租金是 \$90。

(a) 浩信有 \$285。他最多可以租攤位多少天？(只須寫出答案)

3

$$285 \div 90 = 3(\text{天}) \cdots \$15$$

他最多可以租攤位 3 天。

[2 分]

(b) 浩信的攤位的編號是一個兩位數。該數是 16 的倍數，並能被 10 整除。該攤位的編號是什麼？(只須寫出答案)

[2 分]

80

16 的倍數有：16, 32, 48, 64, 80, 96, 110.....

個位數字為 0 的整數能被 10 整除。

(c) 根據以上跳蚤市場的平面圖，服裝區在零食區的西南方。如果浩信想從零食區走到玩具區，他應該向哪個方向走？

(只須寫出答案)

[2 分]

東南

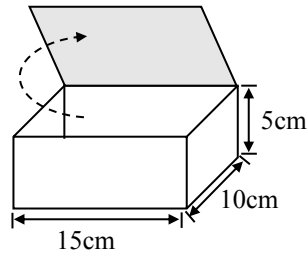

Figure 1

圖一

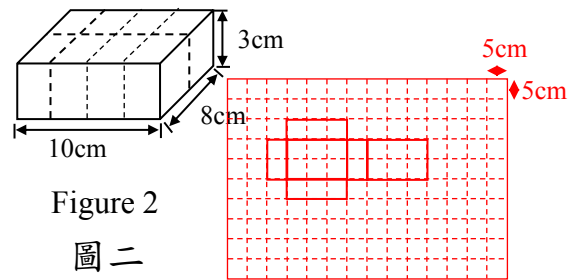

Figure 2

圖二

(Accept any other correct answer)

(其他正確答案也可接受)

36. (a) Mother bought a red bean cake and put it into the cuboid paper box shown in Figure 1. Complete the net of this paper box on the answer sheet. [2 marks]

- (b) Mother divided the red bean cake into eight portions evenly along the dotted line, as shown in Figure 2. What was the volume of each portion of red bean? [4 marks]

The volume of each portion of red bean cake was
 $10 \times 8 \times 3 \div 8$
 $= 30(\text{cm}^3)$

- (c) The weight of the whole red bean cake was 750g, The weight of red bean and sugar weigh 275g and 25g respectively. What was the fraction of the total weight of red bean and sugar to that of the whole red bean cake? (Give the answer only) [2 marks]

$$\frac{2}{5}$$

The fraction was: $\frac{275+25}{750} = \frac{2}{5}$

36. (a) 媽媽買了一塊長方體的紅豆糕，並把它放入圖一的長方體紙盒內。在答案紙上完成這個紙盒的摺紙圖樣。 [2分]

- (b) 媽媽沿着虛線把紅豆糕平均分成8份，如圖二所示。每份紅豆糕的體積是多少？ [4分]

每份紅豆糕的體積是
 $10 \times 8 \times 3 \div 8$
 $= 30(\text{cm}^3)$

- (c) 整塊紅豆糕的重量是 750g，紅豆和糖的重量分別是 275g 和 25g。紅豆和糖的總重量佔整塊紅豆糕的幾分之幾？ (只須寫出答案) [2分]

$$\frac{2}{5}$$

佔整塊紅豆糕的： $\frac{275+25}{750} = \frac{2}{5}$

End of Test Paper

測驗卷完